



# **PBR PANEL**

## **INSTALLATION GUIDE**

## Information

- Claims.....3
- Returns.....3
- Storage.....3
- Handling.....3
- Foot Traffic.....3
- Safety.....3
- Field Cutting Panel.....3

## Substrate and Structure

- Condition of Substrate and Structure.....4

## PBR Installation

- Installation.....5

## Roof Maintenance Installation

- Installation.....6
- Roof Maintenance.....6

## Fastener Selection Guide

- Fastener Selection Guide.....7
- Proper Installation of Gasketed Fasteners.....7

## Material Specifications

- PBR Material Specifications.....8
- Application Details.....8

## Load Tables

- 26 Gauge.....9
- 24 Gauge.....9

## Warranty Information

- Warranty Information.....10

## Trim Profiles

- Trim Profiles.....11

## Flashing Details

- Vented Ridge Cap.....13
- Non-Vented Ridge Cap.....13
- Hip/Ridge.....14
- Front Cap.....14
- Gable.....15
- Eave.....15
- F & J Trim / ½" Trim.....16
- Endwall.....16
- Sidewall.....17
- Snow Stop.....17
- Inside Corner.....18
- Outside Corner.....18
- Window Drip Cap.....19
- Upper Transition.....19
- Lower Transition.....20
- W-Valley.....20
- Z-Base.....21
- Z-Flashing.....21
- Prow Gable.....22
- Overall Dormer.....22
- Ridge Tie-In.....23
- Valley Tie-In.....23



This guide has been provided as a reference and helpful tool for installing Teton Steel's PBR Panel. The installation details shown may not apply to all building designs, codes, or product applications. It is the responsibility of the installer to ensure the details meet code in his/her area.

Teton Steel reserves the right to change any information in this guide, at any time, without notice. If you have any questions or concerns, please contact your Teton Steel representative.

## Claims

It is the responsibility of the customer to review the condition and quantities of an order upon pick up or delivery. Claims for any shortages or damages must be filed immediately for orders picked up, or within 48 hours for orders delivered. Teton Steel will not be held responsible for any claims led after these time frames.

## Returns

Teton Steel does not accept returns of any custom ordered materials, special ordered accessories, or fabricated metal products. Only stock accessories may be returned if they are deemed to be in resalable condition. Stock items being screws (full bag quantities), ashers, closures, clips, underlayment, etc. A restocking fee of 15% may be applied to all returned merchandise.

## Storage

If the metal panels or trim are not used immediately, the metal should be stored in a well ventilated, cool, dry place. This will inhibit moisture build up on the panels and trim, which can lead to white rust.

If the product cannot be stored indoors, elevate one end of the bundle to allow any moisture to run off the panels. Also, a tarp should be loosely wrapped around the bundle, ensuring there is good air flow around the panels. Never store panels in direct contact with the ground.

Teton Steel assumes no responsibility for materials that are not stored properly.

## Handling

Handle all panels and trim with care to avoid damage. When unbundling panels, do not drag one panel against another. This can cause scratches across the panels. When moving the panels, they should be carried vertically to the ground by grasping the edge of the panel carefully to ensure that no excessive bending occurs. Note, the edge of the panel is sharp, and gloves should always be worn when handling all metal.

When handling trim it is important to do so with care and ease. Many trim profiles are fragile and can be easily damaged if not handled appropriately. It is recommended that the installer or whomever is handling trim wear gloves and use two hands at all times.

## Foot Traffic

Care of metal panels and trim must be exercised throughout installation. Foot Traffic can cause distortion of the panel and damage the finish. Foot traffic should be kept to an absolute minimum. Installers should wear soft soled shoes that will help with traction on the roof and prevent scratching.

When walking on the panels is unavoidable, walk in the flats only. Walking on the major ribs can damage the panel.

## Safety

Safety should be the main concern when installing any metal project. Each job site presents different hazards, on the ground and the roof; therefore, it is the responsibility of the installer to determine the safest way to install the metal.

Personal protective equipment should be used at all times when handling or installing metal panels and trim (i.e. gloves, safety glasses, pants, long sleeved shirts and hard hats).

Always be aware of your surroundings and use fall protection. Never install metal roofing during windy or stormy days. Metal roofing can become slippery when wet or dusty and extra care needs to be taken if these conditions are present. Wind can create hazardous working situations by getting under the metal panel and pulling the installer off the roof. Metal roofing is very sharp and can cause serious bodily injury if handled inappropriately.

If a safety concern exists on a job site, stop work immediately. Always comply with OSHA safety regulations.

## Field Cutting Panels

Tin Snips, a circular saw, or a nibbler is recommended for field cutting metal panels and trim. Always wear eye and ear protection when cutting metal. When cutting painted metal, ensure the metal particles and fragments do not end up on the painted surface. Metal particles on the painted surface will result in rusting and pitting in that area. Teton Steel recommends the panels to be turned upside down and all cutting be done looking at the backside of the material. Installers should immediately wipe away any debris from the material after cuts to prevent this problem. Panels should be cut in an area where metal particles do not end up on other panels or building materials.

*\*Failure to remove the metal particles from the panel will void any warranty*

## CONDITION OF SUBSTRATE AND STRUCTURE

Before the installation process begins, it is critical that the framing and substrate are inspected to ensure that the structure is square and plumb. If it is not, it will have to be corrected. Make sure any structural fixes are done by someone with the proper experience and knowledge. Correct any objectionable warp, waves, or buckles in the substrate before proceeding with panel installation. The roof panels will follow the contour of the structure and may appear irregular if not corrected.

To check the structure for squareness, take two diagonal measurements from the corner to corner. The roof is square if the two measurements are equal.

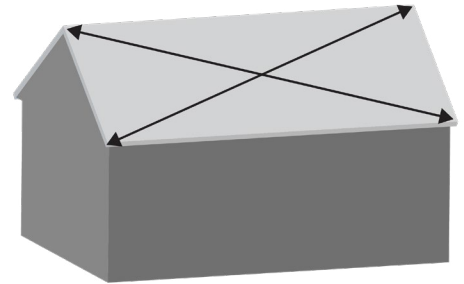

If the roof is not square, follow the 3-4-5 method to ensure that the panel is being installed square. If the first panel is not installed square, all remaining panels will also be out of square when attached to the structure.

|   |  |
|---|--|
| 1 | To do this, pick a starting point at the bottom corner of the roof, about a foot away. Set a nail there.                             |
| 2 | From the nail, measure exactly 3 feet in the opposite direction along the bottom edge of the roof. Insert another nail in that spot. |
| 3 | From the first nail, measure exactly 4 feet up the slope of the roof and draw a small arc.   |
| 4 | Measure from the second nail up to the arc measuring exactly 5 feet, drawing another arc.  |
| 5 | Attach a chalk line to the first nail and extend it up the slope to it passes through the intersection of the two arcs.              |
| 6 | Snap the chalk line. This line is now square with the bottom edge of the roof.   |
| 7 | Use this line to properly install the first panel square on the roof. <sup>1</sup>   |

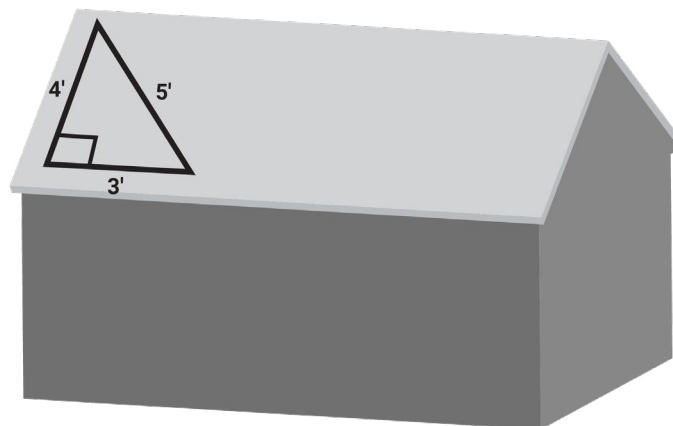

<sup>1</sup>For larger roofs, this method can be done with multiples of 3,4,5. Example 6', 8', 10'

## INSTALLATION

Installation over shingles is possible but is not recommended. It is best to remove shingles and install a new, synthetic underlayment to act as a vapor barrier between the substrate and the metal. If shingles will not be removed, furring strips need to be installed on the roof at 2'-0" centers. The metal panels will then be fastened to the furring strips.

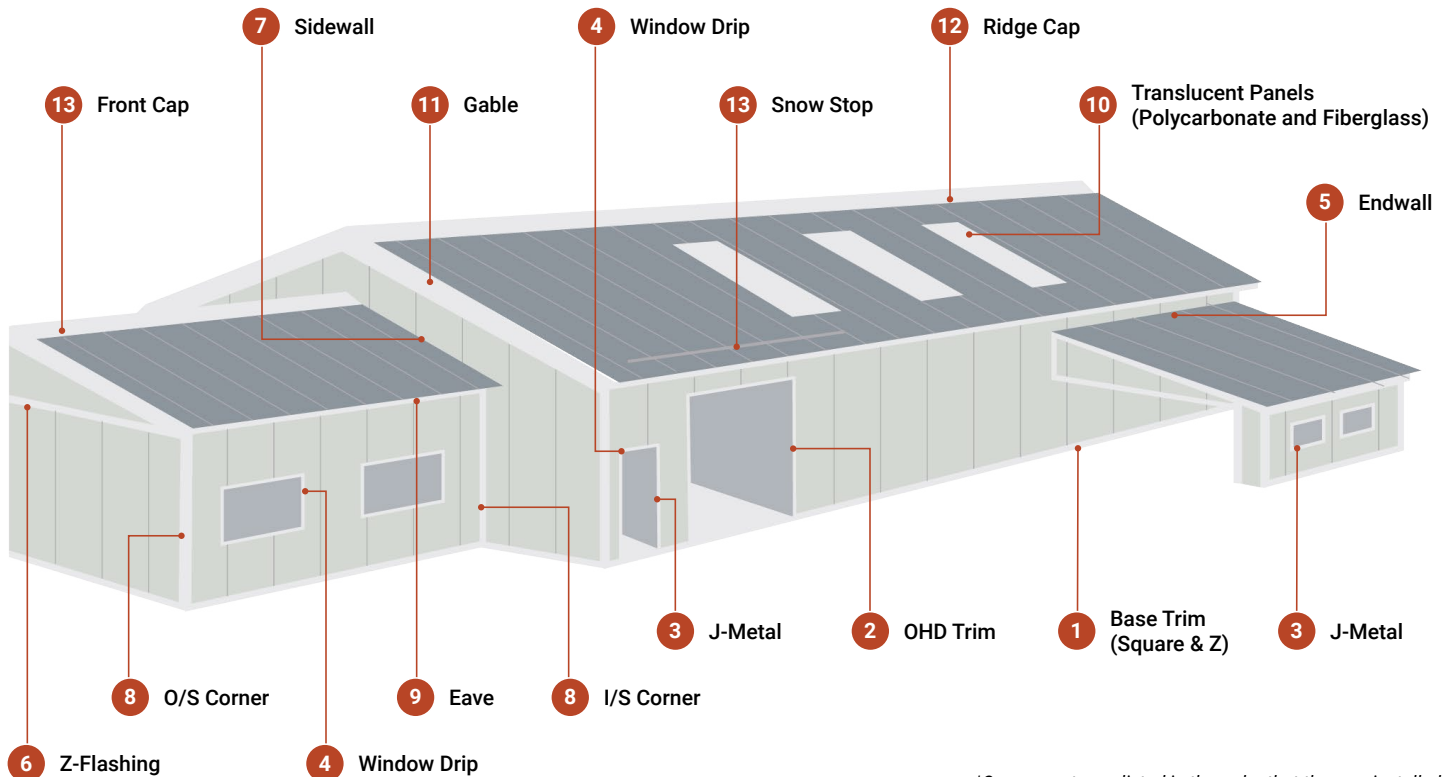

*\*Components are listed in the order that they are installed.*



### TOOLS & EQUIPMENTS

- Hard Hat
- Gloves
- Safety Glasses
- Ear Plugs
- Fall Protection
- Screw Gun
- Tin Snips
- Tape Measure
- Chalk Line
- Electric Nibbler
- Circular Saw
- Angle Grinder
- Rivet Gun

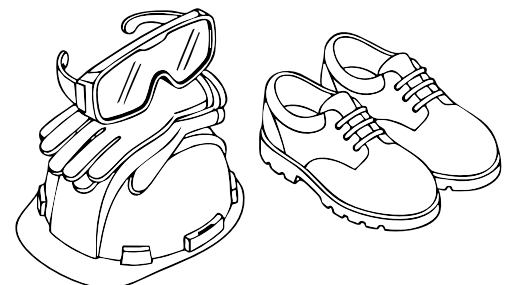

## INSTALLATION

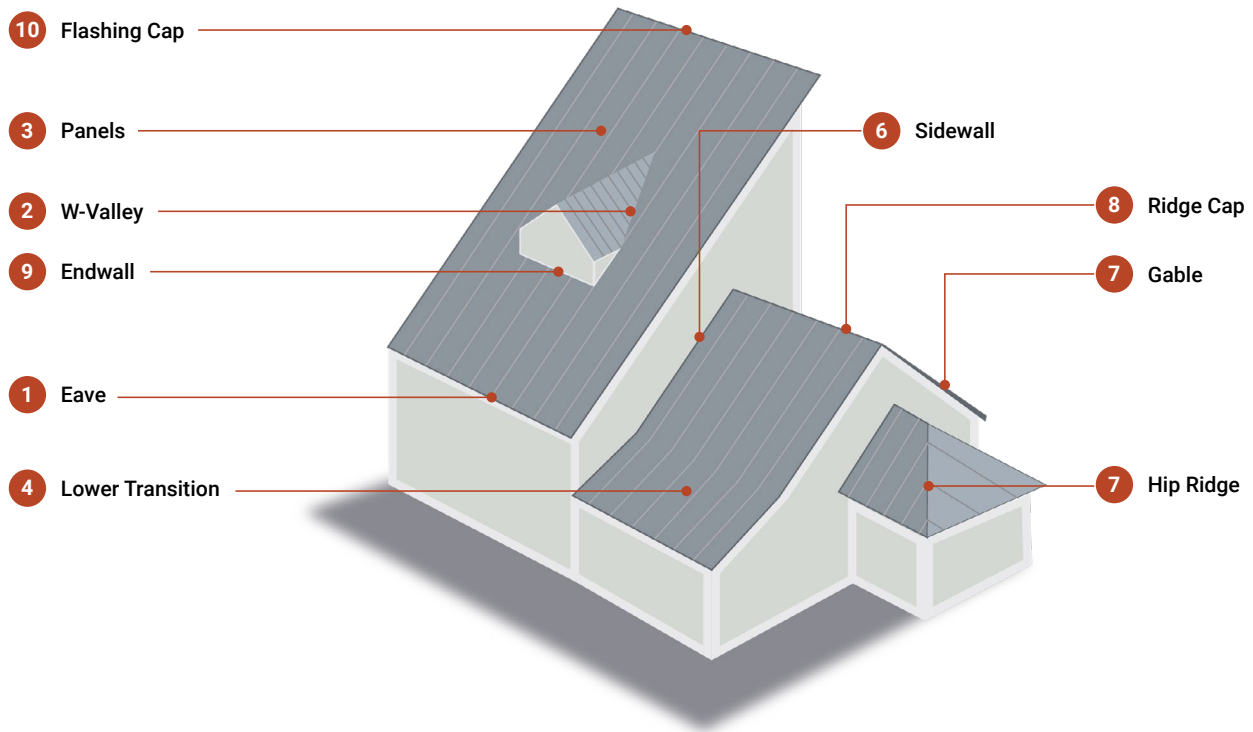

*\*Components are listed in the order that they are installed.*

## ROOF MAINTENANCE

Roof maintenance should be done, at the minimum, annually. These steps will ensure that your roof will have a longer lifespan with less maintenance and help prevent costly repairs. It is best to perform roof maintenance when the weather permits safe working conditions.

- Clear all debris off the roof (dirt, rocks, branches, leaves, etc.)
- Clean out all drains and gutters to ensure proper drainage, to prevent water standing.
- Remove any overhanging branches or anything else that could penetrate the roof surface.
- Inspect all areas for leaks and deterioration - pay attention to stains and discoloration of the roof edges and surrounding walls as they are possible indications of a leak.
- Check roof penetrations for possible leaks and cracks in caulking.

If exposed fasteners have been used to install the roof, it is crucial they are inspected annually.<sup>2</sup>

1. Check if they are installed correctly.
2. Ensure that they are not fastened too tight or not tight enough.
3. Inspect the integrity of the neoprene washer.

<sup>2</sup>Refer to Fastener selection guide on the following pages.

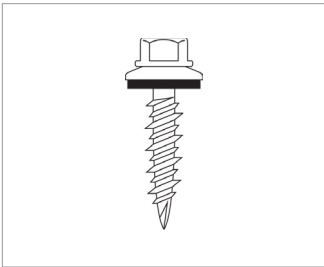

### WOODFAST SCREW

- No. 10 x 15, Type 17**  
**Available sizes: 1", 1 ½", 2", 2 ½", 3"**
- ¼" Hex Head
  - Use: Panel to dimensional lumber and trim attachment.

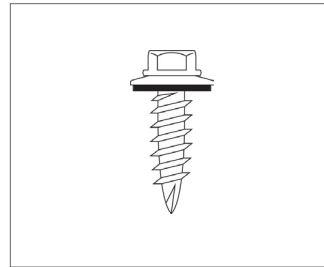

### WAFER SCREW

- No. 14 x 10, Type 17**  
**Available sizes: 1", 1 ½"**
- 5/16" Hex Head
  - Use: Panel to plywood/ OSB substrate and trim attachment.

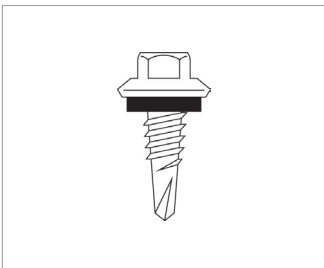

### LAP TEK

- No. 14 x 7/8"**  
**Available size: 7/8"**
- 5/16" Hex Head
  - Use: Trim attachment and stitching lap Seams together.
- \*Compatible with No. 12 Tek Screw and No. 14 Wafer Screw*

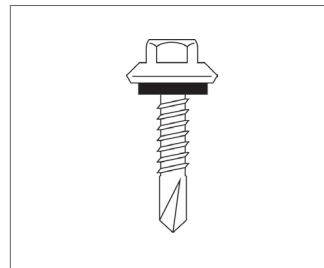

### TEK SCREW

- No. 14 x 10, Type 17**  
**Available sizes: 1", 1 ½"**
- 5/16" Hex Head
  - Use: Panel to plywood/ OSB substrate and trim attachment.

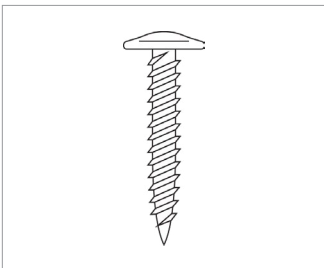

### PANHEAD

- 10 x 12**  
**Available sizes: 1", (1 ½" and 2" available by special order)**
- Phillips Head
  - Use: To fasten standing seam panels and trim to wood deck (unexposed).

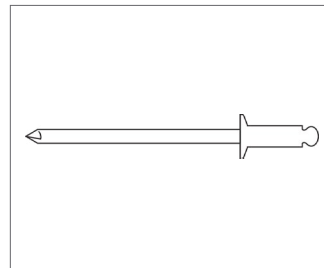

### STAINLESS STEEL RIVET POP RIVET

- Available sizes: 1/8" x 3/16"**
- 5/16" Hex Head
  - Use: Panel to plywood/ OSB substrate and trim attachment.



## PROPER INSTALLATION OF GASKETED FASTENERS

This table shows the fasteners available for Teton Steel. Refer to the panel installation and flashing details of this manual for specific screw usage and spacing.

- ✓ Panel attachment screws must be long enough to fully penetrate through the wood roof decking, steel purlins or penetrate solid lumber at least one inch.
- ✓ Exposed fasteners must have sealing washers and should be the same color as the parts they attach.
- ✓ Screws must be properly driven to ensure proper seal and holding strength. Do not underdrive or overdrive the screws.
- ✓ All screws must be coated to provide protection against corrosion.
- ✓ Stainless steel rivets are not watertight.

## PBR MATERIAL SPECIFICATIONS

| PBR MATERIAL SPECIFICATIONS |   |
|-----------------------------|---|
| <b>Gauges</b>               | 26, 24  |
| <b>Weight</b>               | 2.67lbs/LnFt (26)   3.58lbs/LnFt (24)   |
| <b>Substrate</b>            | G-90, Grade 80 (26), AZ50, Grade 50 (24)  |
| <b>Paint System</b>         | Storm Shield™, Ceranamel™XT-40S, Certified Cool, Energy Star® Rated, Silicone Modified Polyester  |
| <b>Warranties</b>           | Ceranamel™XT-40S<br>40 Years Galvalume – 20 years   |
| <b>Materials</b>            | Painted, Galvalume  |
| <b>Minimum Slope</b>        | 3:12, 5:12 with Mastic Tape and Stitch Screws installed 1'0" up the panel at all overlaps   |
| <b>Testing</b>              |  <ul style="list-style-type: none"> <li>• UL 580 Wind Uplift (Class 90)</li> <li>• UL 2218 Class 4 Hail Impact</li> <li>• UL 790 Class A Fire Rating</li> </ul> |

### Profile Details

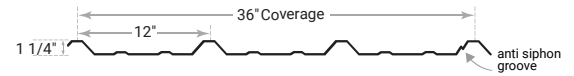

### Screw Patterns

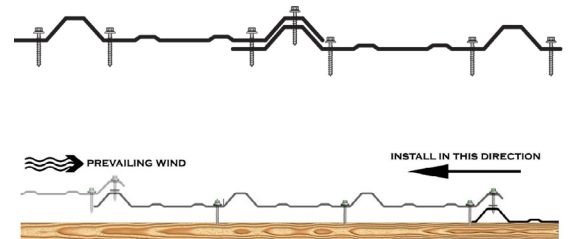

## APPLICATION DETAILS

| FASTENER GUIDE  |
|---|
| #10 Woodfast screws are designed for use with dimensional lumber.   |
| #14 Wafer screws are designed for use with plywood sheeting, OSB, and wafer wood (7/16" minimum thickness). |
| #12 Tek Screws are designed to be used with structural steel up to 3/16" in thickness.                      |

| FASTENER APPLICATION:  |
|--|
| <p>Screws are to be applied next to every rib and then up the panel, no more than 5'0". On low slope roofs, Mastic Tape must be applied between the panel side laps with Stitch Screws installed every 1'0" up the panel.</p> <p><i>*At the eave or end laps, a double screw pattern should be used with screws applied to both sides of the rib</i></p> |



**Please Note:** It is the responsibility of the builder to ensure that purlins are adequately spaced to meet specific engineering requirements.

\*Teton Steel is neither partially or solely responsible for improper installation or defects as a result of installation.

## 26 GAUGE (0.0181") Fy = 60 ksi, Fu = 61.5 ksi

| SPAN TYPE | LOAD TYPE            | SPAN IN FEET |       |       |       |       |       |       |
|-----------|----------------------|--------------|-------|-------|-------|-------|-------|-------|
|           |                      | 3.0          | 4.0   | 5.0   | 6.0   | 7.0   | 8.0   | 9.0   |
| 1-span    | NEGATIVE WIND LOAD   | 126.37       | 71.08 | 45.49 | 31.59 | 23.21 | 17.77 | 14.04 |
|           | LIVE LOAD/DEFLECTION | 125.69       | 70.7  | 38.51 | 22.28 | 14.03 | 9.4   | 6.6   |
| 2-span    | NEGATIVE WIND LOAD   | 120.59       | 69.04 | 44.56 | 31.09 | 22.91 | 17.57 | 13.9  |
|           | LIVE LOAD/DEFLECTION | 117.33       | 69.4  | 44.8  | 31.25 | 23.03 | 17.66 | 13.97 |
| 3-span    | NEGATIVE WIND LOAD   | 148.17       | 85.44 | 55.34 | 38.68 | 28.53 | 21.9  | 17.34 |
|           | LIVE LOAD/DEFLECTION | 133.33       | 85.87 | 55.62 | 38.89 | 28.68 | 19.34 | 13.58 |
| 4-span    | NEGATIVE WIND LOAD   | 139.13       | 80.03 | 51.77 | 36.16 | 26.66 | 20.46 | 16.19 |
|           | LIVE LOAD/DEFLECTION | 128.33       | 80.43 | 52.04 | 36.35 | 26.81 | 20.57 | 14.45 |

## 24 GAUGE (0.0223") Fy = 50 ksi, Fu = 60 ksi

| SPAN TYPE | LOAD TYPE            | SPAN IN FEET |       |       |       |       |       |       |
|-----------|----------------------|--------------|-------|-------|-------|-------|-------|-------|
|           |                      | 3.0          | 4.0   | 5.0   | 6.0   | 7.0   | 8.0   | 9.0   |
| 1-span    | NEGATIVE WIND LOAD   | 133.48       | 75.08 | 48.05 | 33.37 | 24.52 | 18.77 | 14.83 |
|           | LIVE LOAD/DEFLECTION | 119.08       | 52.22 | 26.74 | 15.47 | 9.74  | 6.53  | 4.58  |
| 2-span    | NEGATIVE WIND LOAD   | 114.41       | 66.59 | 43.33 | 30.37 | 22.44 | 17.24 | 13.66 |
|           | LIVE LOAD/DEFLECTION | 105.6        | 71.09 | 46.37 | 32.55 | 24.07 | 18.51 | 13.88 |
| 3-span    | NEGATIVE WIND LOAD   | 138.49       | 81.62 | 53.46 | 37.61 | 27.86 | 21.44 | 17    |
|           | LIVE LOAD/DEFLECTION | 120          | 86.91 | 57.11 | 34.86 | 21.95 | 14.71 | 10.33 |
| 4-span    | NEGATIVE WIND LOAD   | 130.7        | 76.7  | 50.12 | 35.22 | 26.06 | 20.05 | 15.89 |
|           | LIVE LOAD/DEFLECTION | 115.5        | 81.75 | 53.58 | 37.71 | 23.77 | 15.93 | 11.18 |

- Strength Calculations based on the 2012 AISI Standard "North American Specification for the Design of Cold-formed Steel Structural Members."
- Allowable loads are applicable for uniform loading and spans without overhangs.
- LIVE LOAD/DEFLECTION load capacities are for those loads that push the panel against its support. The applicable limit states are flexure, shear, combined shear and flexure, web crippling at end and interior supports, and a deflection limit of L/180 under strength-level loads.
- NEGATIVE WIND LOAD capacities are for those loads that pull the panel away from its supports. The applicable limit states are flexure, shear, combined shear and flexure, and a deflection limit of L/60 under 10-year wind loading.
- Panel pullover and Screw pullout capacity must be checked separately using the screws employed for each particular application when utilizing this load chart.
- Effective yield strength has been determined in accordance with section A2.3.2 of the 2012 NAS specification.
- The use of any accessories other than those provided by the manufacturer may damage panels, void all warranties and will void all engineering data.
- This material is subject to change without notice please contact Teton Steel for most current data.

The Engineering data contained herein is for the expressed use of customers and design professionals. Along with this data, it is recommended that the design professional have a copy of the most current version of the **North American Specification for the Design of Cold-Formed Steel Structural Members** published by the American Iron and Steel Institute to facilitate design. The Specification contains the design criteria for cold formed steel components. Along with the Specification, the designer should reference the most current building code applicable to the project jobsite in order to determine environmental loads. If further information or guidance regarding cold-formed design practices is desired, please contact the manufacturer.

\*Teton Steel is neither partially or solely responsible for improper installation or defects as a result of installation.



# Warranty Information



## Dura Coat Products Inc. Ceranamel™ XT-40S 40 Year Limited Warranty

Ceranamel XT-40S™

Dura Coat Products, Inc. provides the following warranty concerning the use of Dura Coat's Ceranamel™ XT-40S system for roofing and sidewall applications.

Dura Coat Products, Inc. (Dura Coat) warrants that the Ceranamel™ XT-40S system, including primer and backer, when applied over primer properly cleaned and chemically treated Aluminum, Hot Dipped Galvanized Steel (G-60 minimum), and Aluminum/Zinc coated steel in accordance with Dura Coat Products Inc. application and product data sheets, will not under normal atmospheric conditions:

- A. Chip, Crack, Check, or Peel for a period of (40) forty years from date of installation (except for such crazing that may occur on tightly roll-formed edges and brake bends).
- B. Chalk in excess of a numerical rating of (8) for a period of (30) thirty years from date of installation when measured in accordance with the standard procedures outlined in ASTM D-4214 on vertical (sidewall). On horizontal application (roofing), chalk will not exceed a-numerical rating of (6).
- C. Fade or change color in excess of (5) Delta E (Hunter) units for a period of (30) thirty years from date of installation when calculated in accordance with ASTM D-2244. The color change is to be measured on exposed painted surface cleaned of surface soils and oxidation (Chalk), and the corresponding values then measured on the original or exposed painted surface. It is understood that fading or color change may not be uniform if the surfaces are not equally exposed to the sun and elements.

This warranty is restricted to failures resulting from normal weathering and does not include coating failures caused by scratches, scrapes or any other unnatural damage including improperly formed, fabricated or embossed material. Dura Coat accepts no liability for damages caused by acts of God, radiation, falling objects, explosions, or other external forces beyond Dura Coat's control. This warranty does not cover failure due to failure of the substrate.

This warranty excludes failures caused by standing water, and direct exposure to corrosive and aggressive atmospheres including animal waste products. Applications exposed to salt spray or within 1500 feet of the seacoast, must be maintained by washing with fresh water at least biannually and documentation of this maintenance provided upon request. Applications within 1500 feet of the coast line will require a high build primer/topcoat system. Failure to use the high build primer/topcoat system will void the warranty. This warranty does not cover failure due to salt spray corrosion, failure of the substrate.

Dura Coat's responsibility liability is limited, at its option, and extends only to the direct cost of refinishing or replacing failed coated substrate and in no event shall Dura Coat's liability exceed the lesser of the cost of replacing the coated metal or refinishing the metal on site. Dura Coat cannot accept liability for loss or damage to other property or equipment, loss of profits or sales, or any other claims relative to standard business interruption, or any other incidental

or consequential damages. This warranty does not cover, nor does Dura Coat accept any financial responsibility for tear down, removal or reinstallation of roofing, solar panels, or any other attachments previously added to the roof or its surface.

Dura Coat reserves the right to establish whether repainting or replacing material is required and to approve and participate in the negotiation of any subcontracted material replacement, installation, or refinishing. After replacement or re-finishing of the repaired area, this warranty will be for the remainder of the warranty period applicable to the metal originally coated area will be considered as installed as of the original installation date for the purpose of the application of this warranty.

Claims under this warranty must be submitted in writing within forty-five (45) days of discovery of the warranted performance failure. Upon review, Dura Coat may, at its discretion, choose to remediate said claim under the terms and conditions outlined in the warranty document or inspect the project. Dura Coat requires the opportunity for site failure inspection and investigation. Dura Coat also reserves the right to solely evaluate and determine its obligation under the terms and conditions of this limited warranty.

The customer shall maintain, or have access to, adequate records to identify the coil coater, coil numbers, product identification and date of installation. In the event of a claim, Dura Coat reserves the right to inspect all records mentioned above.

This limited warranty supersedes any and all other warranties of performance, expressed or implied, by Dura Coat. Any modifications, additions, or adjustments made to this warranty must be officially added as a signed written amendment.

This warranty is extended to Customer alone at the purchase of the Product and shall not inure to the benefit of any other party. Dura Coat's warranty and name(s) are not to be used in any warranty given by Customer, and Customer shall not permit its agents, representatives, customers, distributors, applicators, or contractors to claim, represent, or imply that this warranty extends to or is available to anyone other than the Customer.

This limited warranty is nontransferable and non-assignable and may not be modified, extended, or enlarged by any representative of Dura Coat or intermediate salesman or agent.

This limited warranty shall be governed by and interpreted in accordance with, the laws of the State of California.

**Rollformed Ridge Cap**

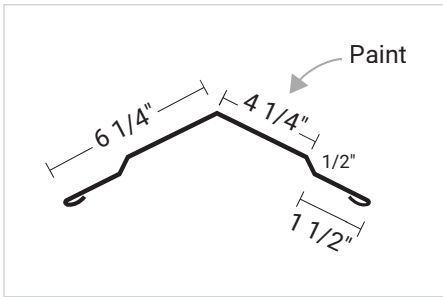

**PBR Sidewall**

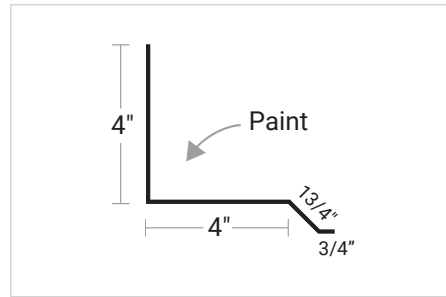

**PBR Inside Corner**

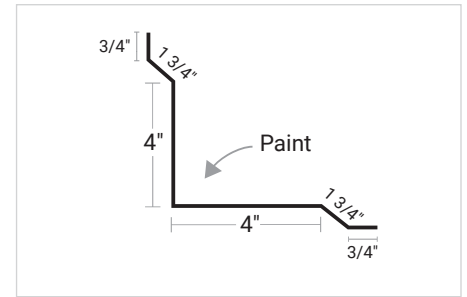

**PBR Gable/Rake**

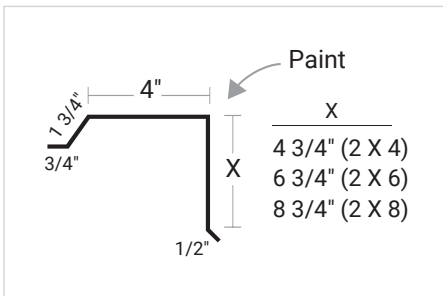

**Endwall**

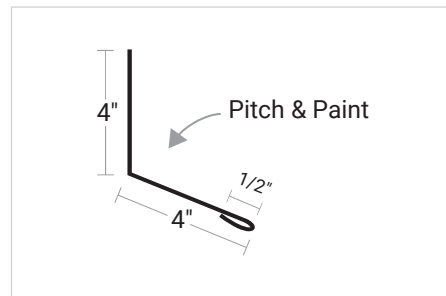

**Pbr Upper Transition**

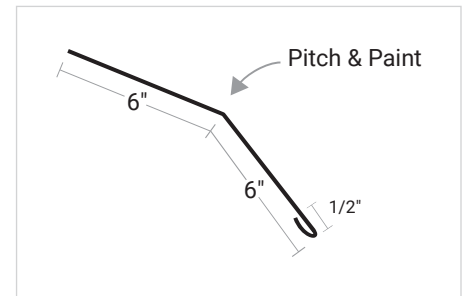

**Eave (Style A Fascia)**

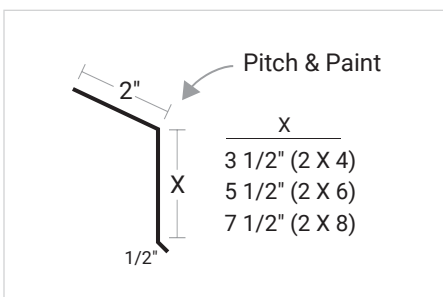

**PBR Outside Corner**

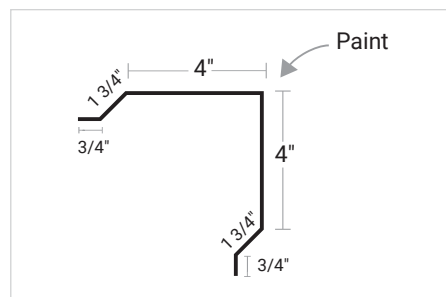

**Door Post Trim**

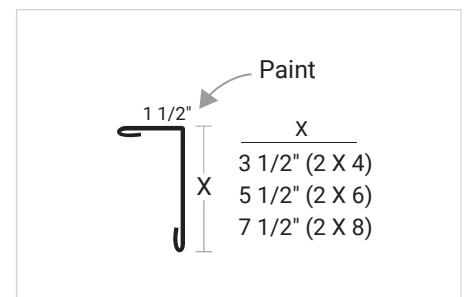

**PBR Front Cap (High Eave)**

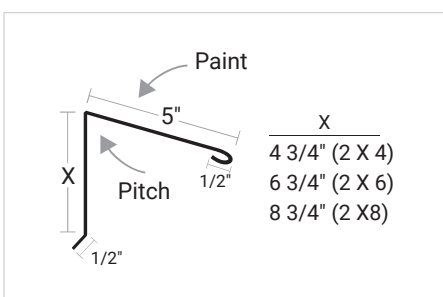

**Hip Ridge**

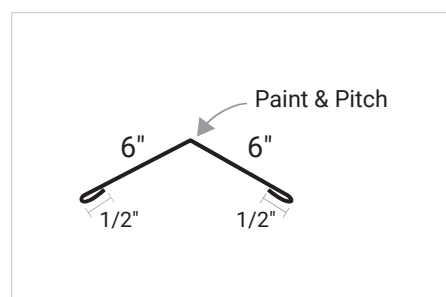

**PBR W-Valley**

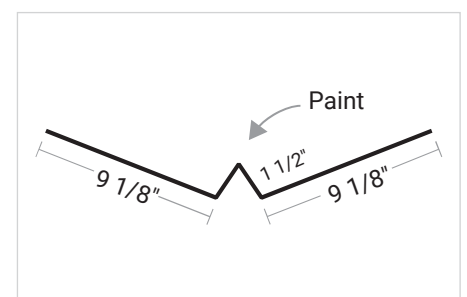

**Lower Transition**

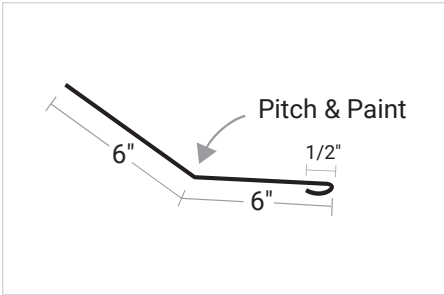

**Snow Stop**

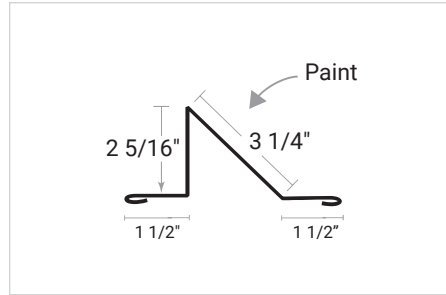

**PBR Z-Flashing**

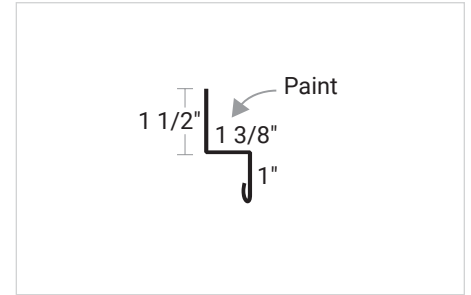

**Style D Eave**

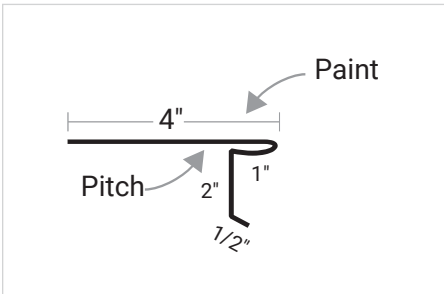

**PBR Square Base Trim**

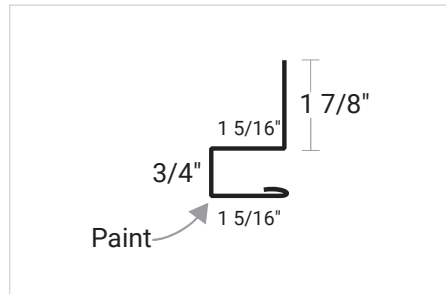

**L-Angle (Channel)**

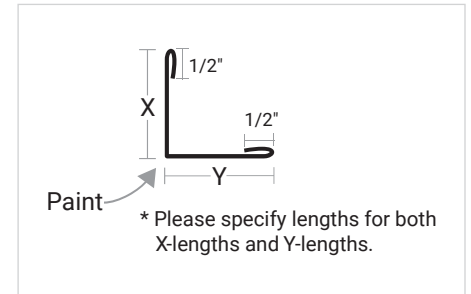

**PBR Z-Base Trim**

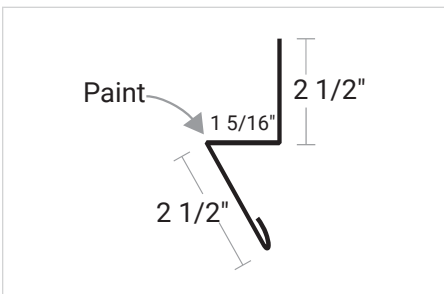

**PBR 1 1/2" Window Drip Cap**

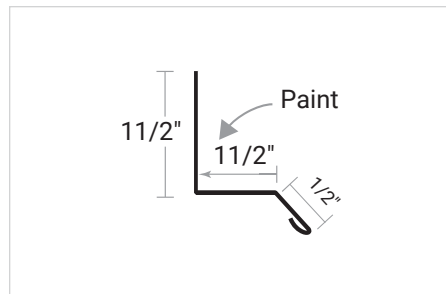

**PBR J-Metal**

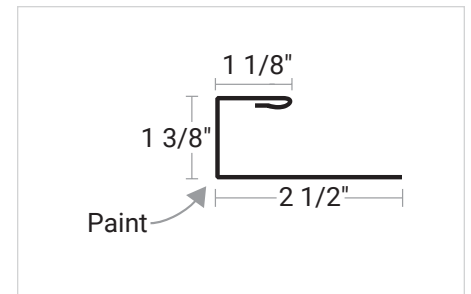

**PBR F+J 1 1/4" x 1/2" (Panel to Soffit)**

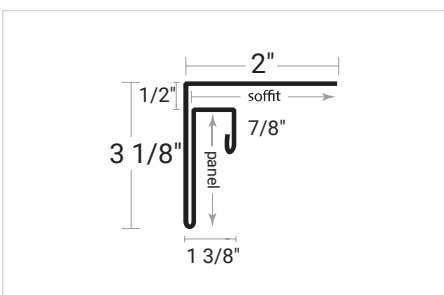

**Profile - Ridge**

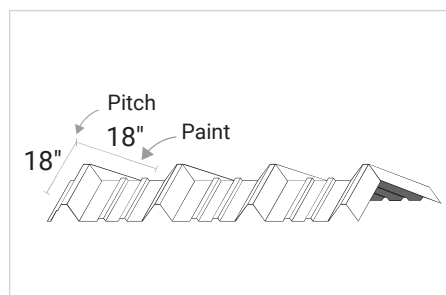

## VENTED RIDGE CAP

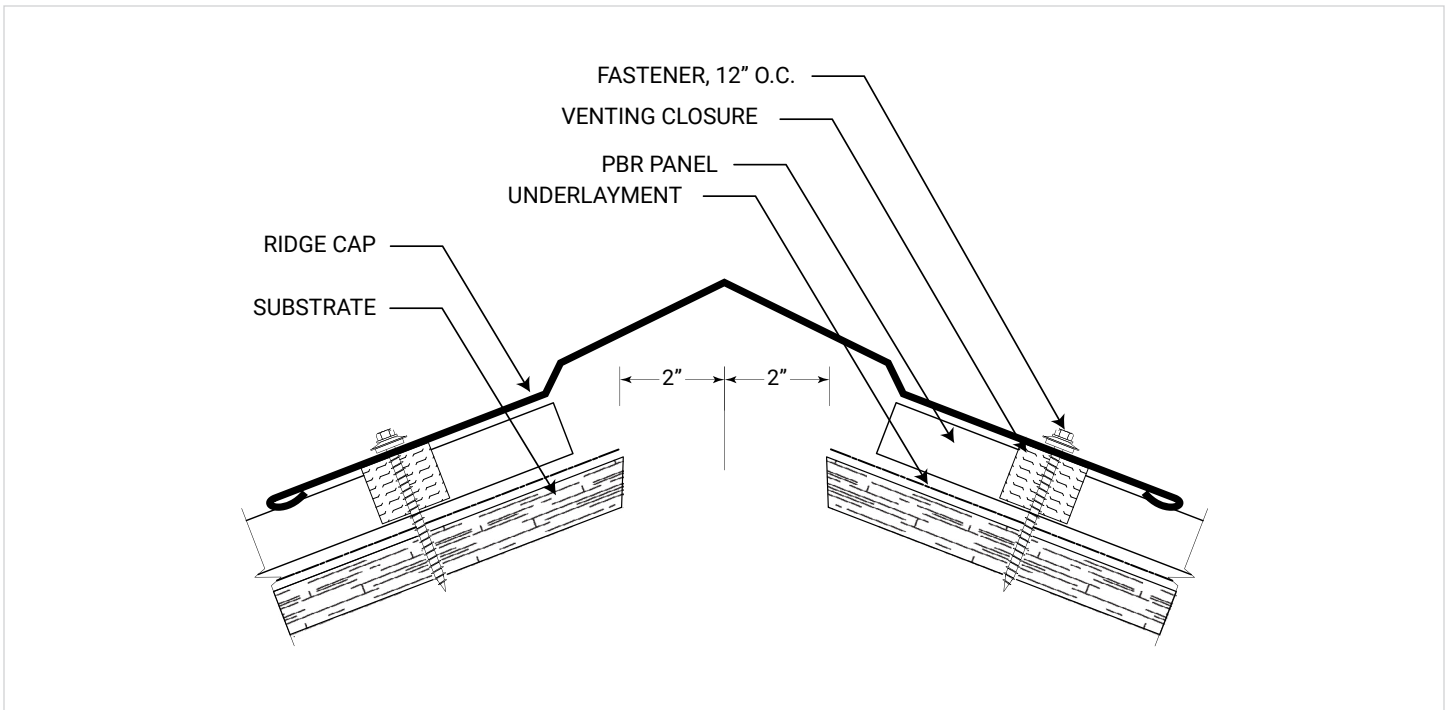

## NON-VENTED RIDGE CAP

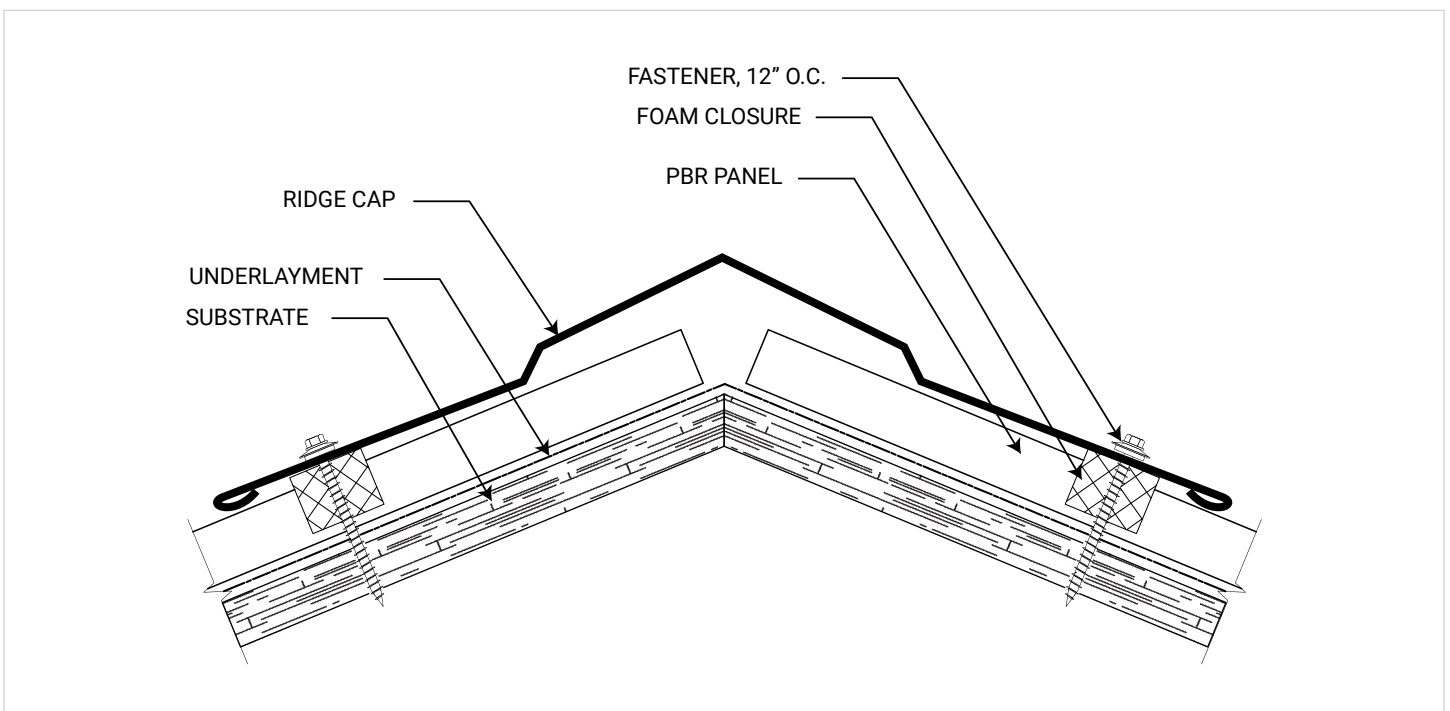

*\*Details are subject to change without notice.*

## HIP/RIDGE

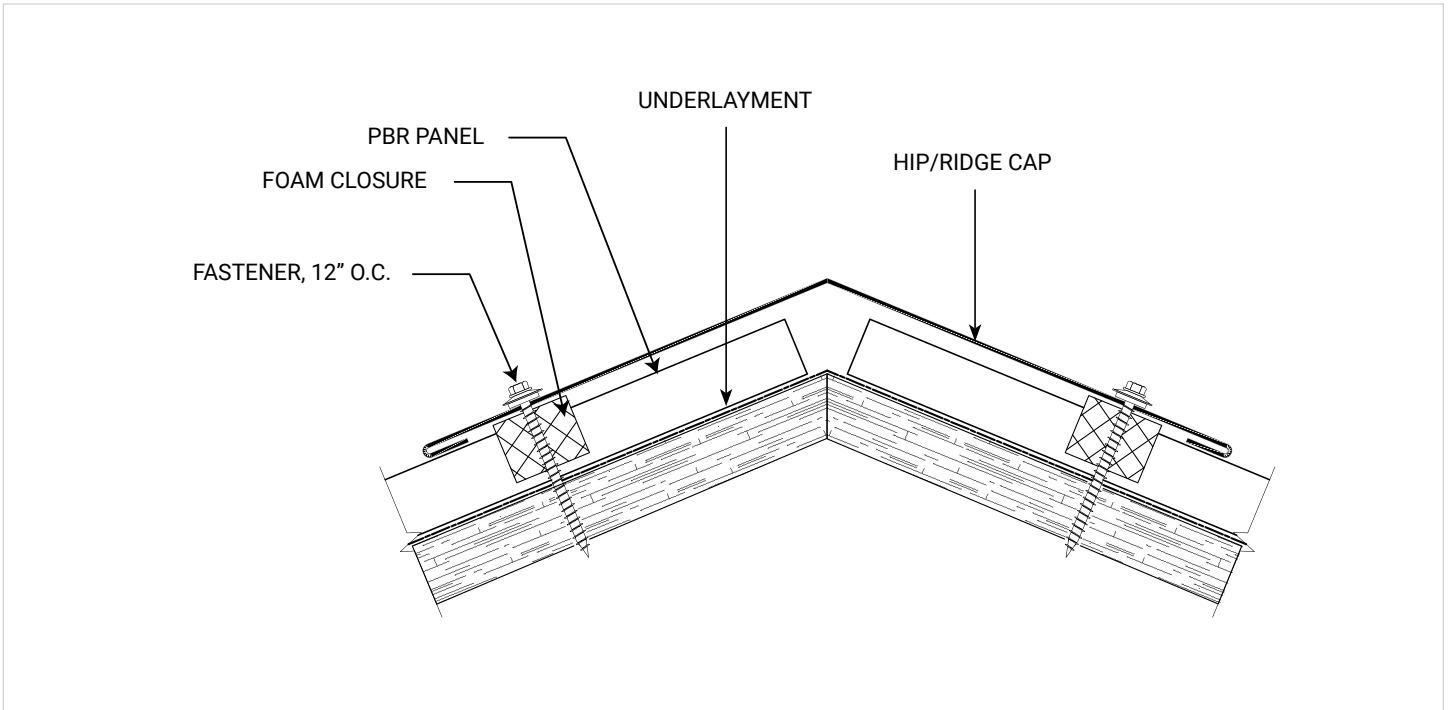

## FRONT CAP

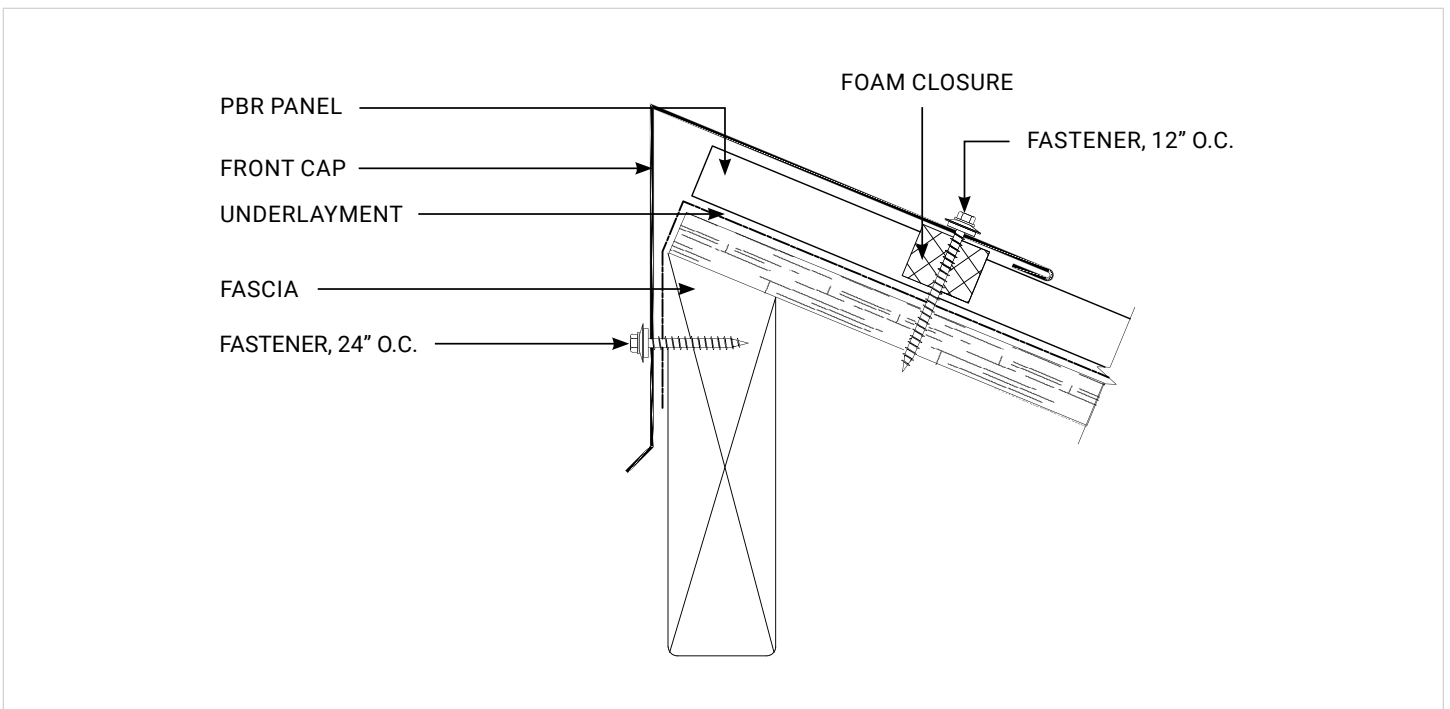

*\*Details are subject to change without notice.*

## GABLE

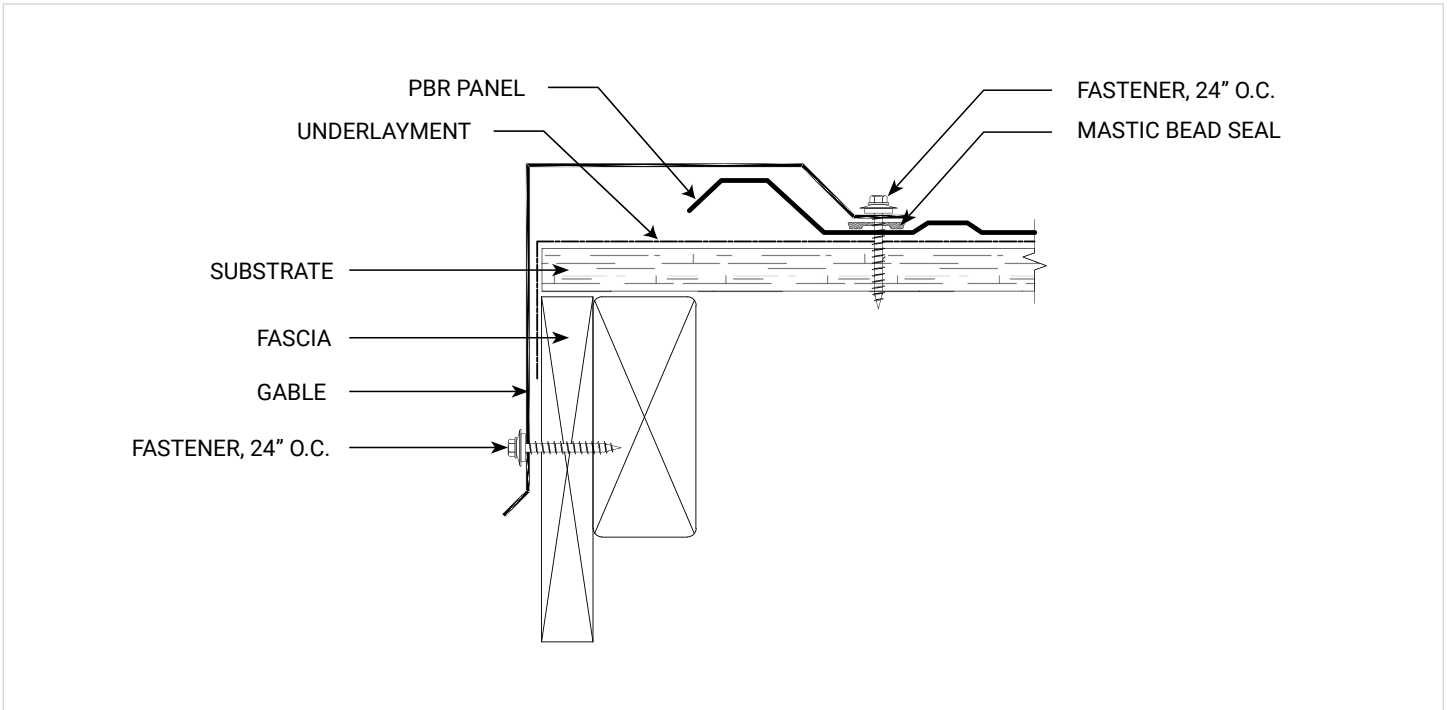

## EAVE

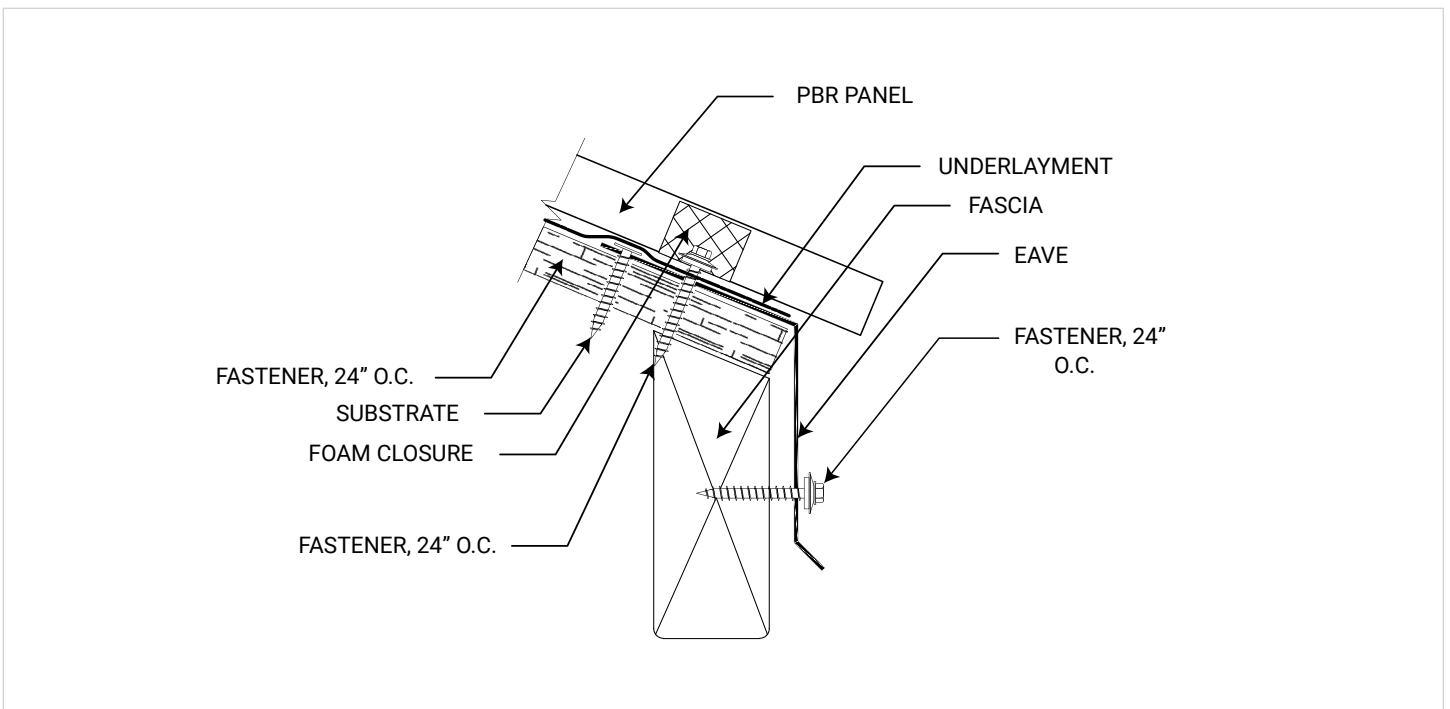

*\*Details are subject to change without notice.*

## F & J TRIM / 1/2" TRIM

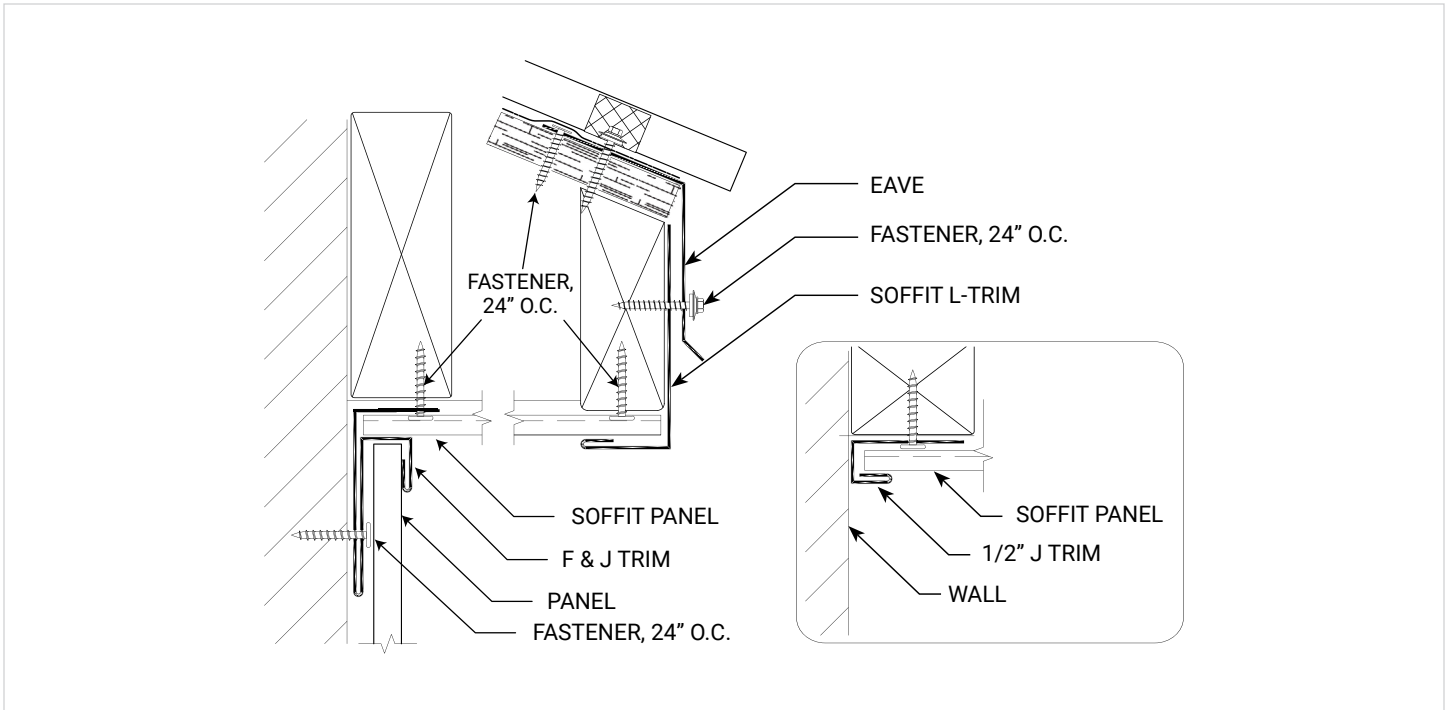

## ENDWALL

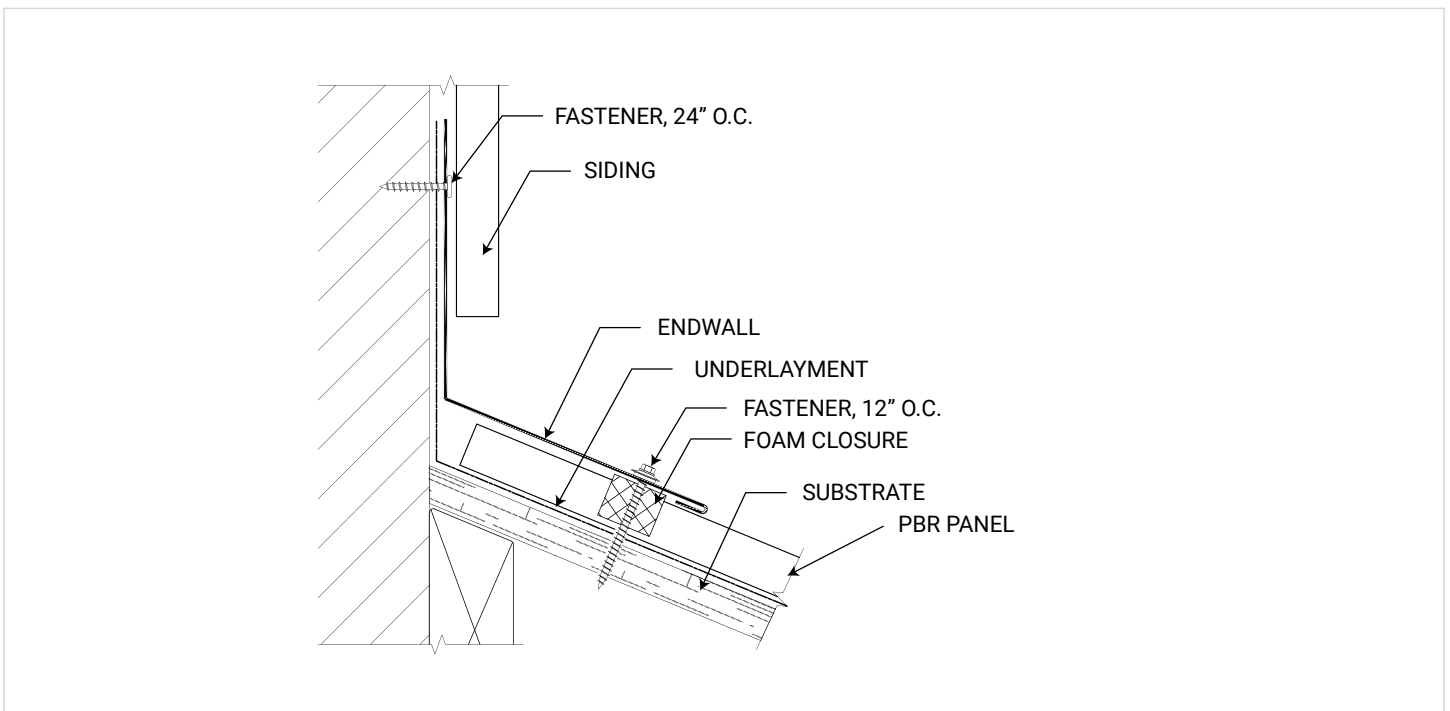

*\*Details are subject to change without notice.*

## SIDEWALL

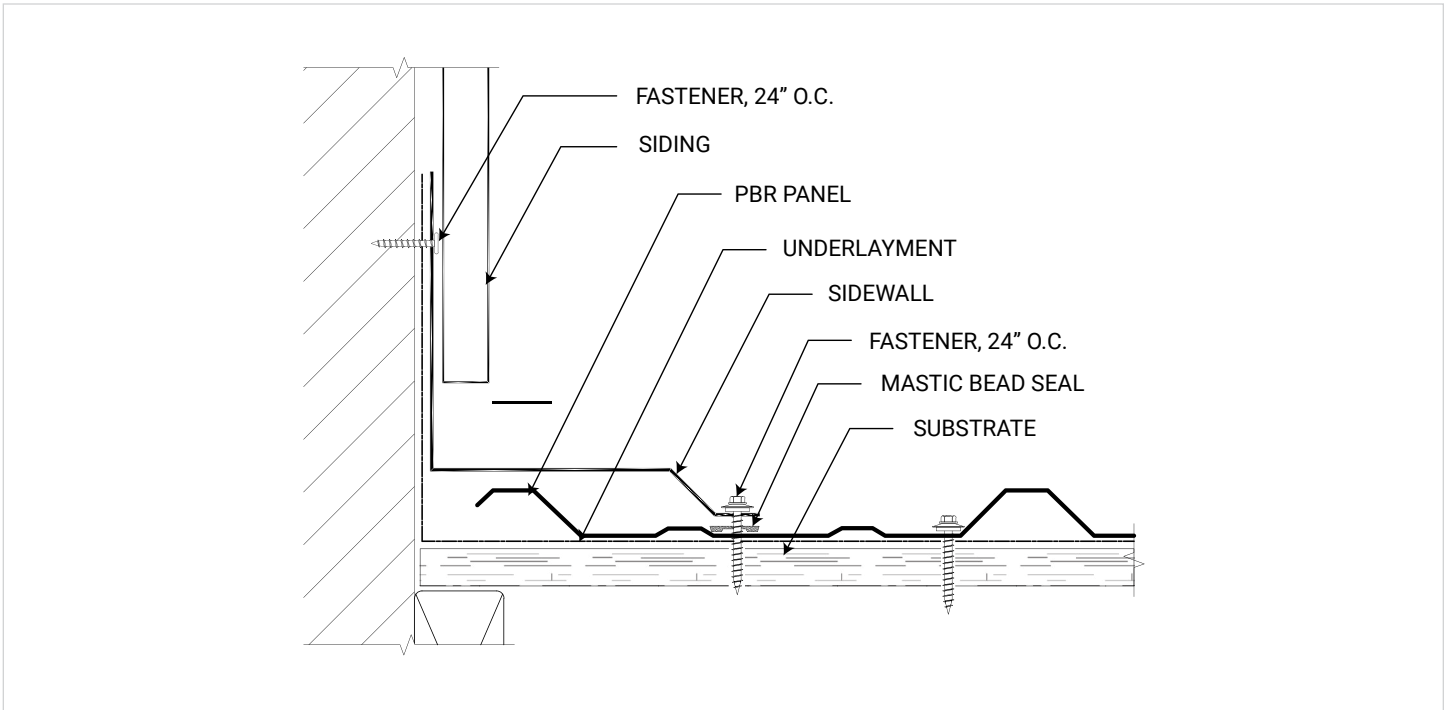

## SNOW STOP

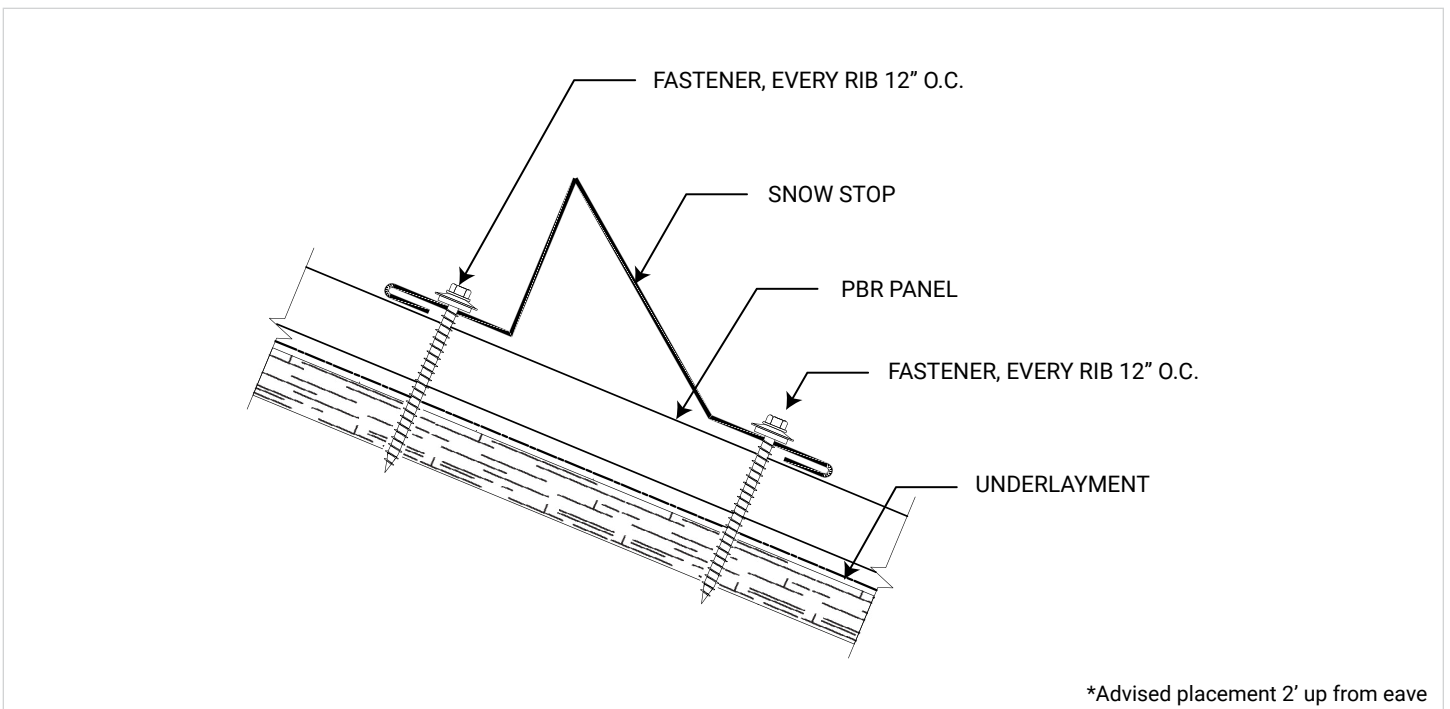

\*Details are subject to change without notice.

## INSIDE CORNER

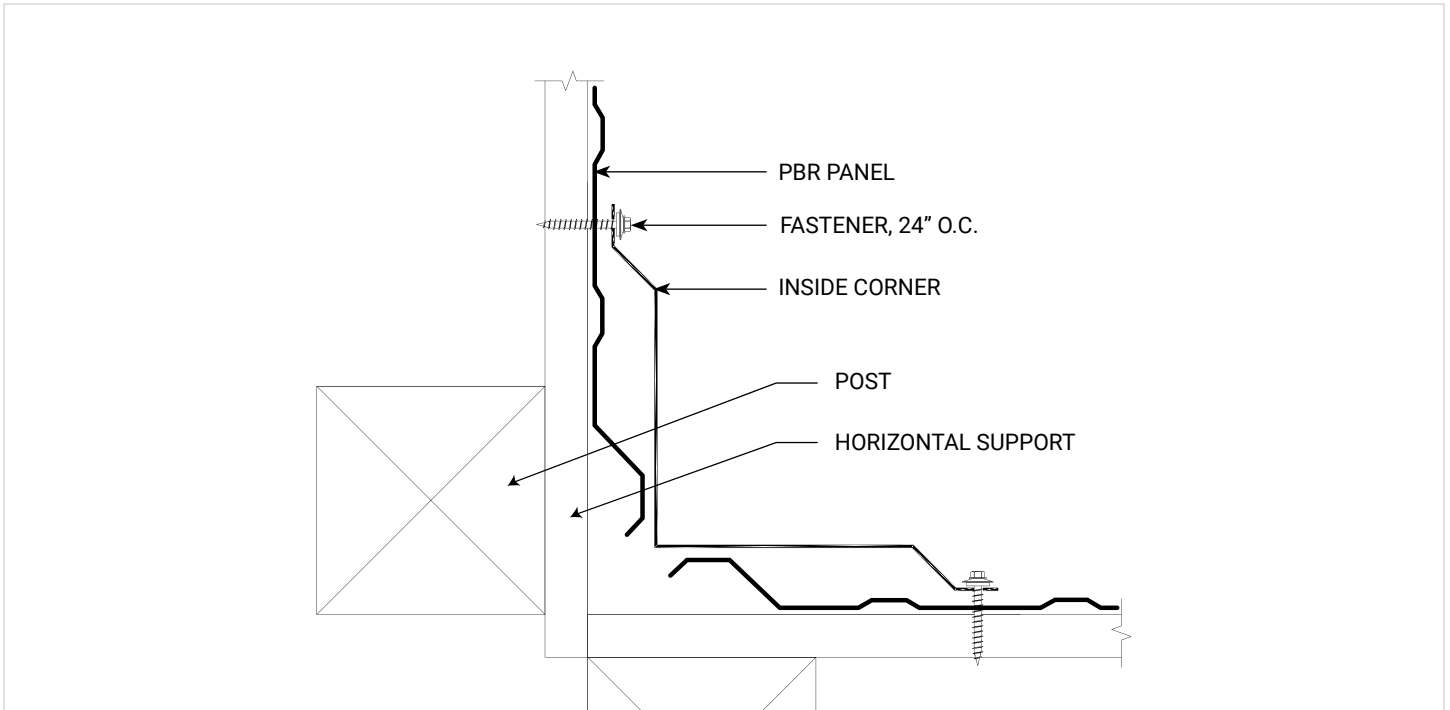

## OUTSIDE CORNER

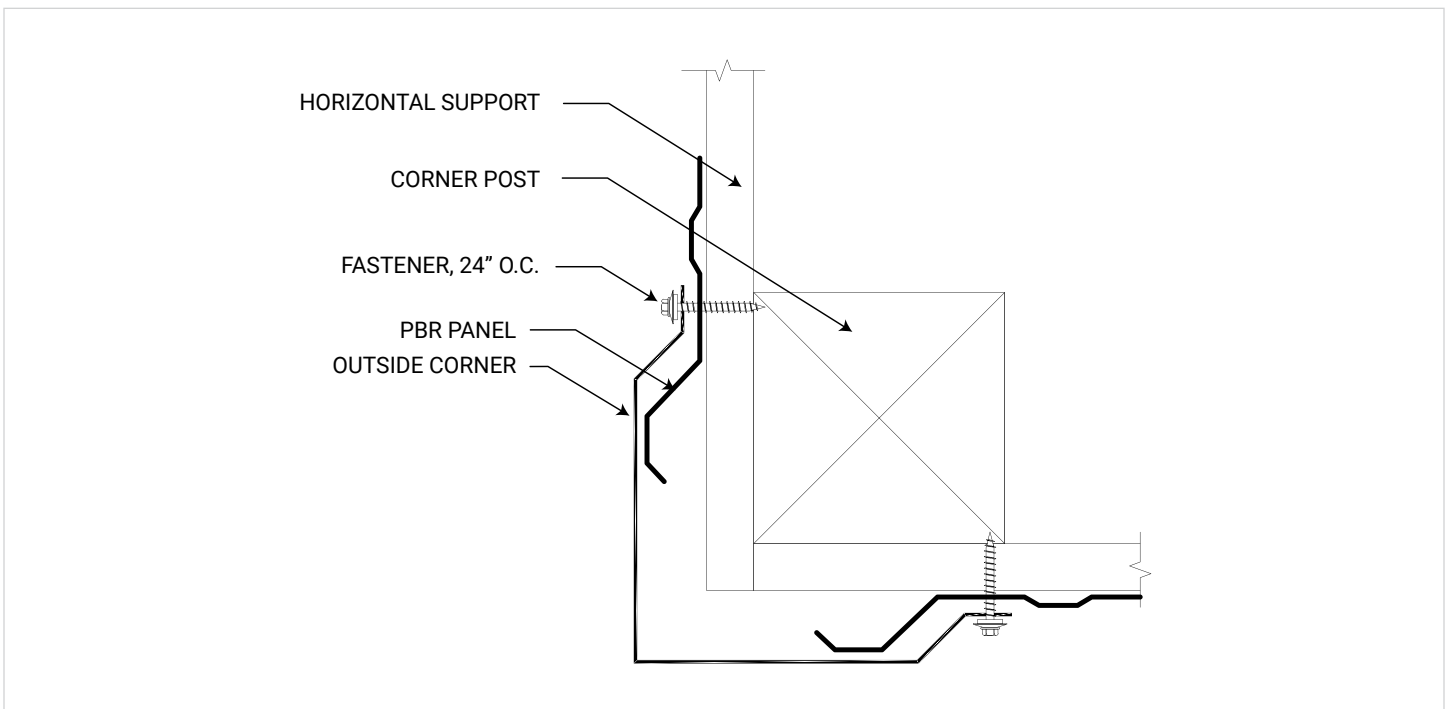

*\*Details are subject to change without notice.*

## WINDOW DRIP CAP

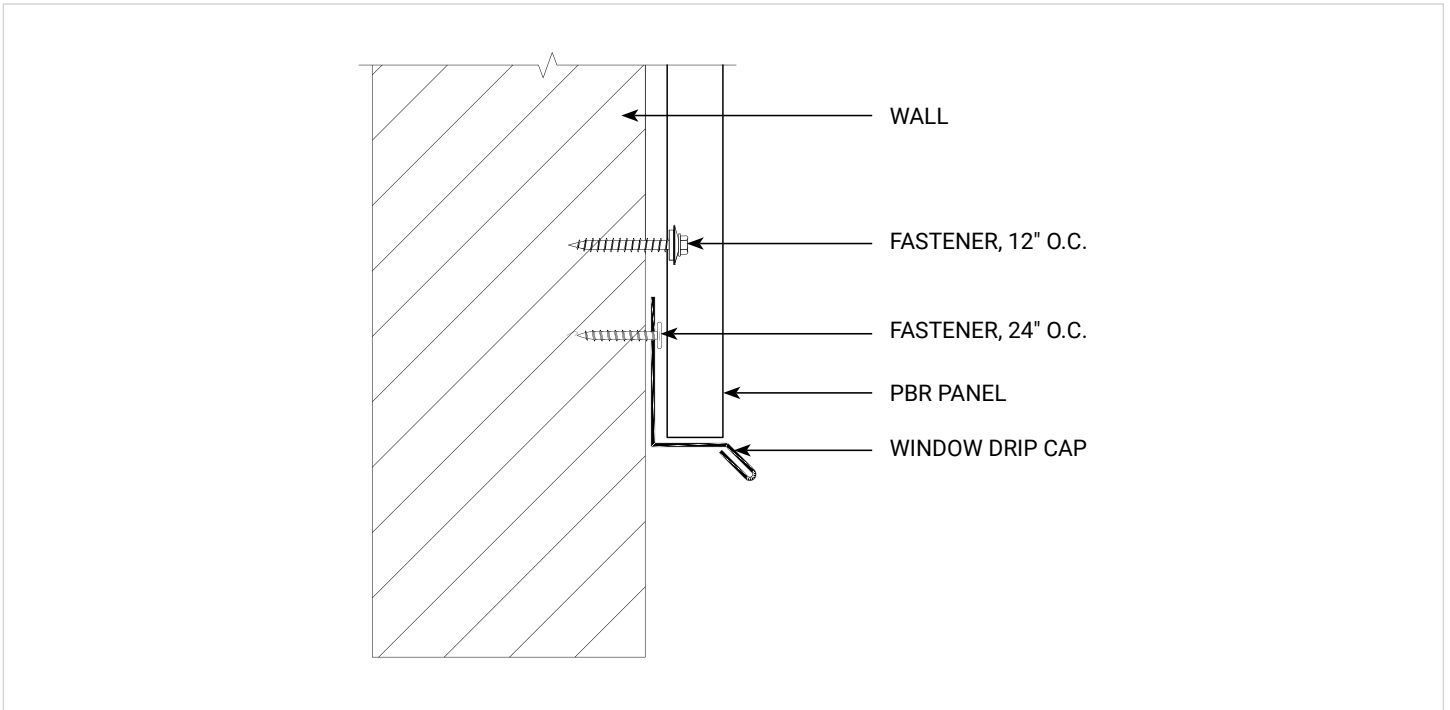

## UPPER TRANSITION

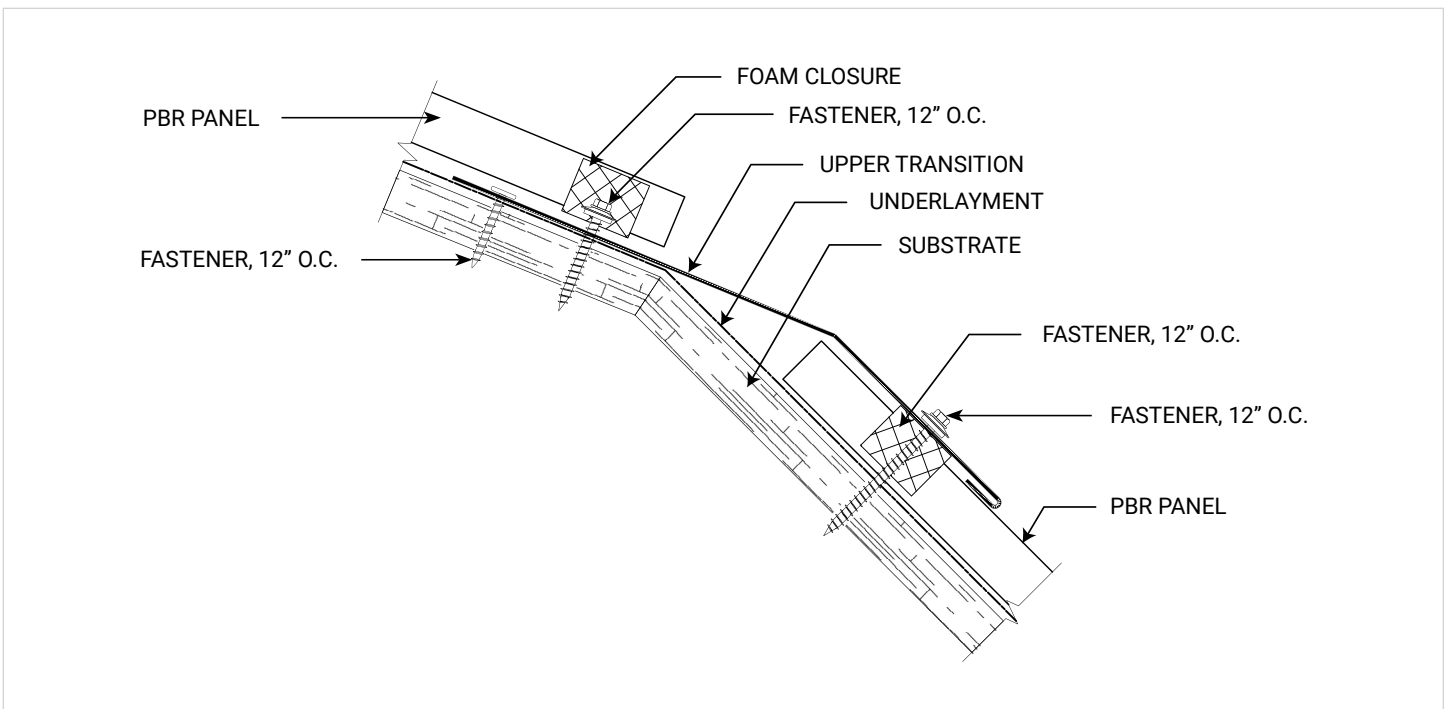

*\*Details are subject to change without notice.*

## LOWER TRANSITION

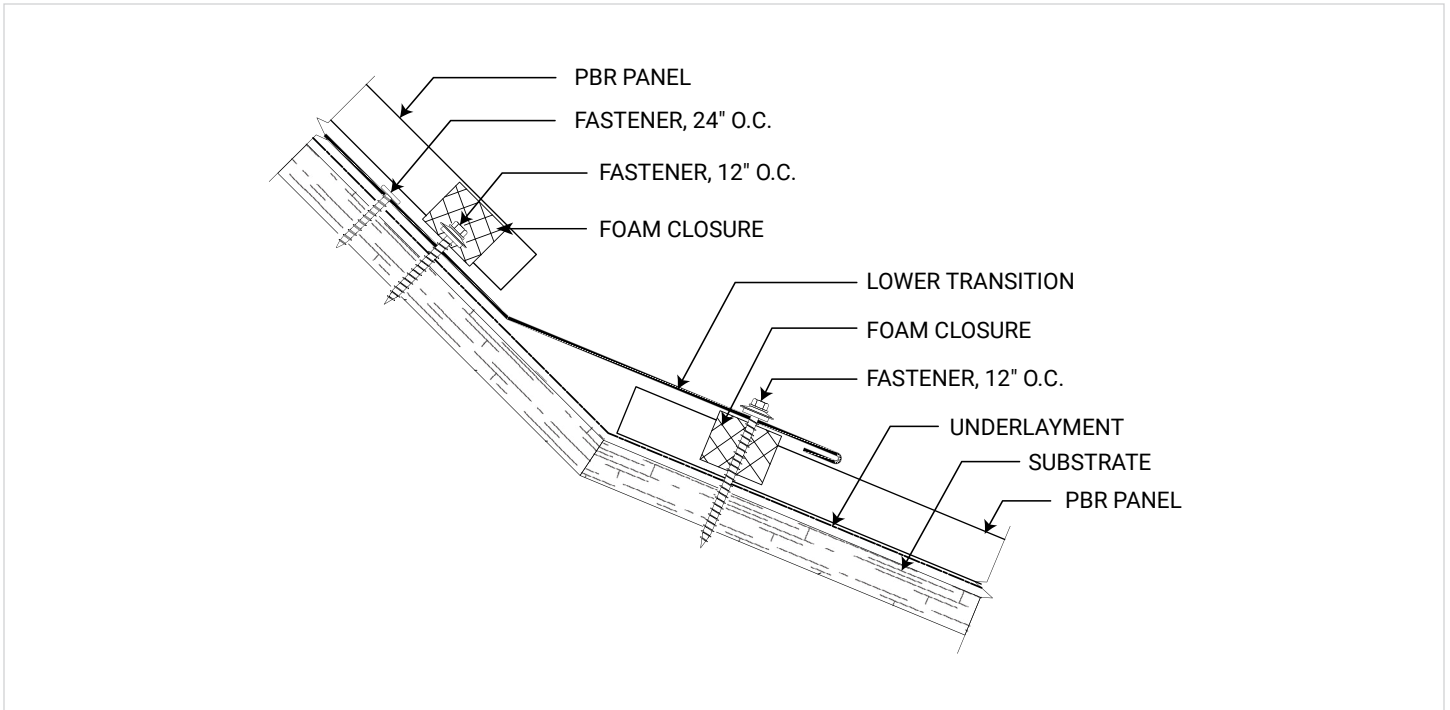

## W-VALLEY

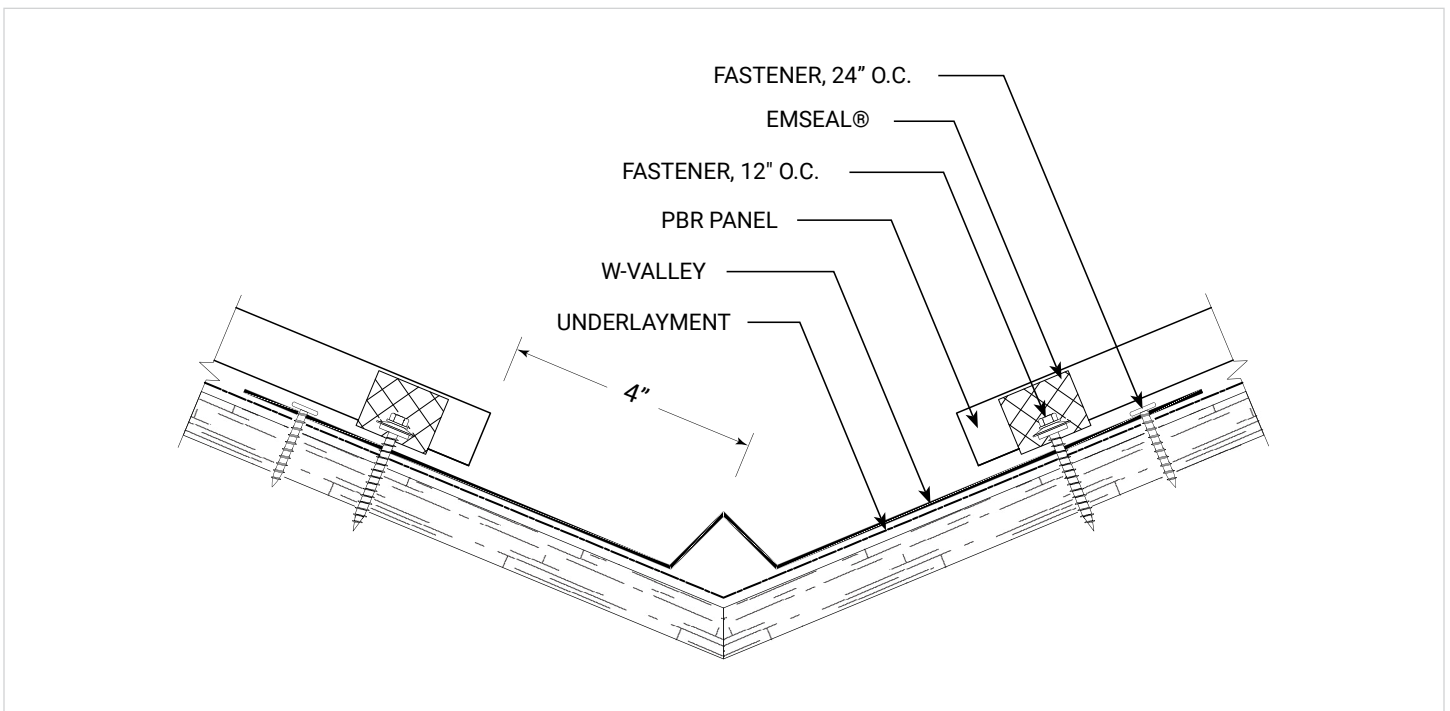

*\*Details are subject to change without notice.*

## Z-BASE

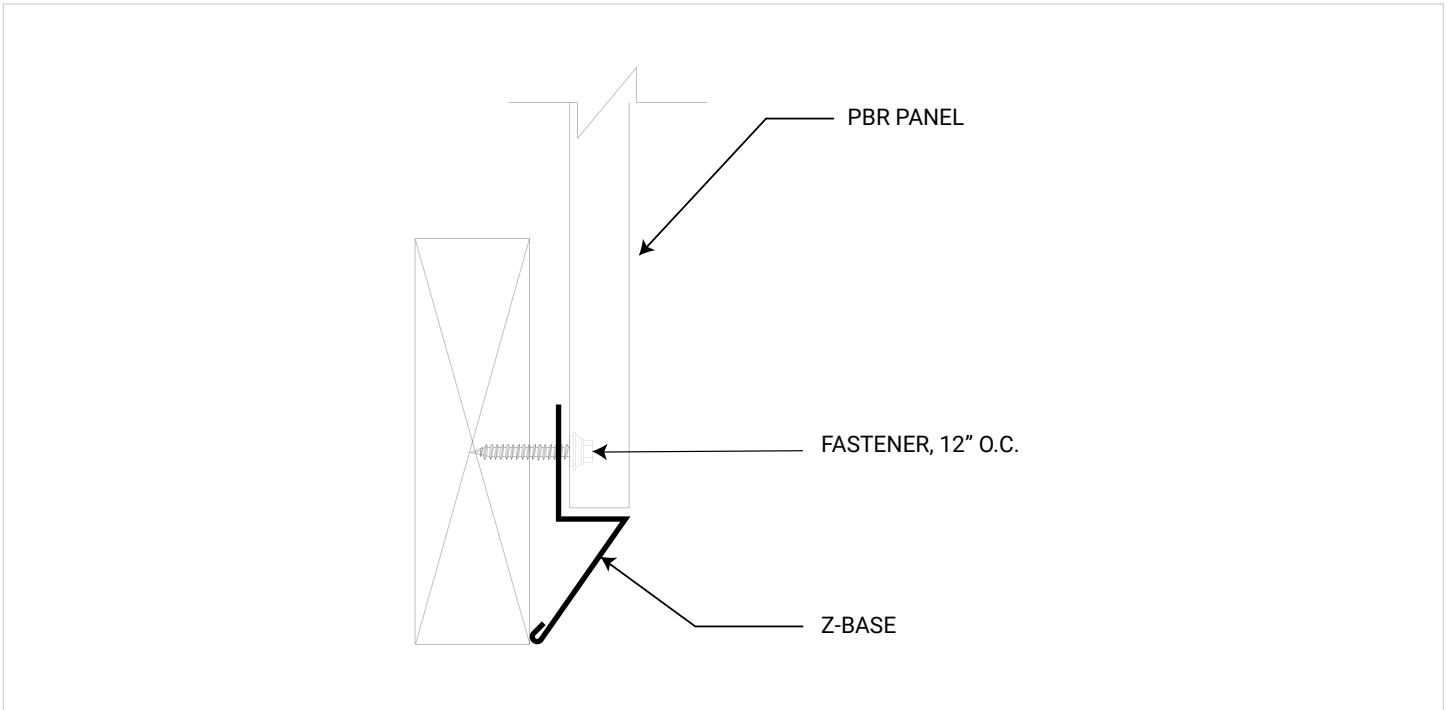

## Z-FLASHING

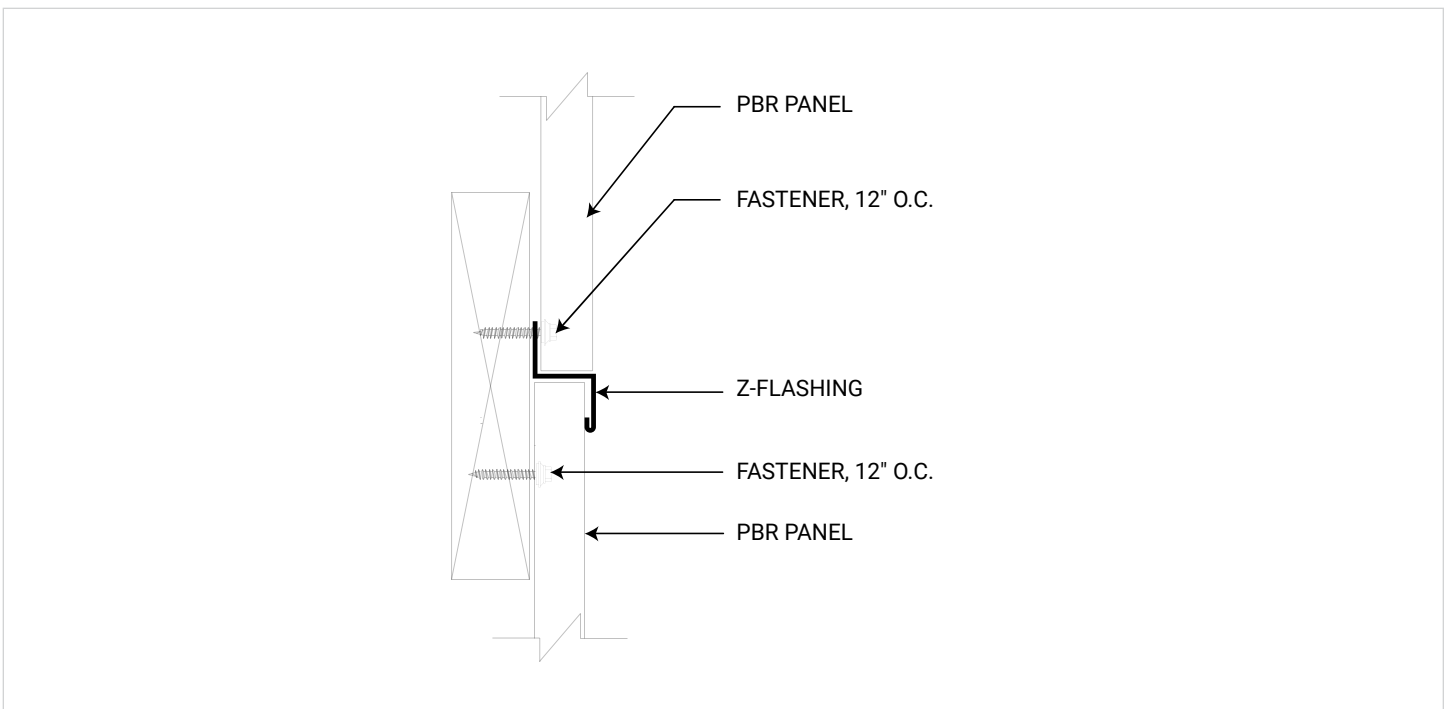

*\*Details are subject to change without notice.*

## PROW GABLE

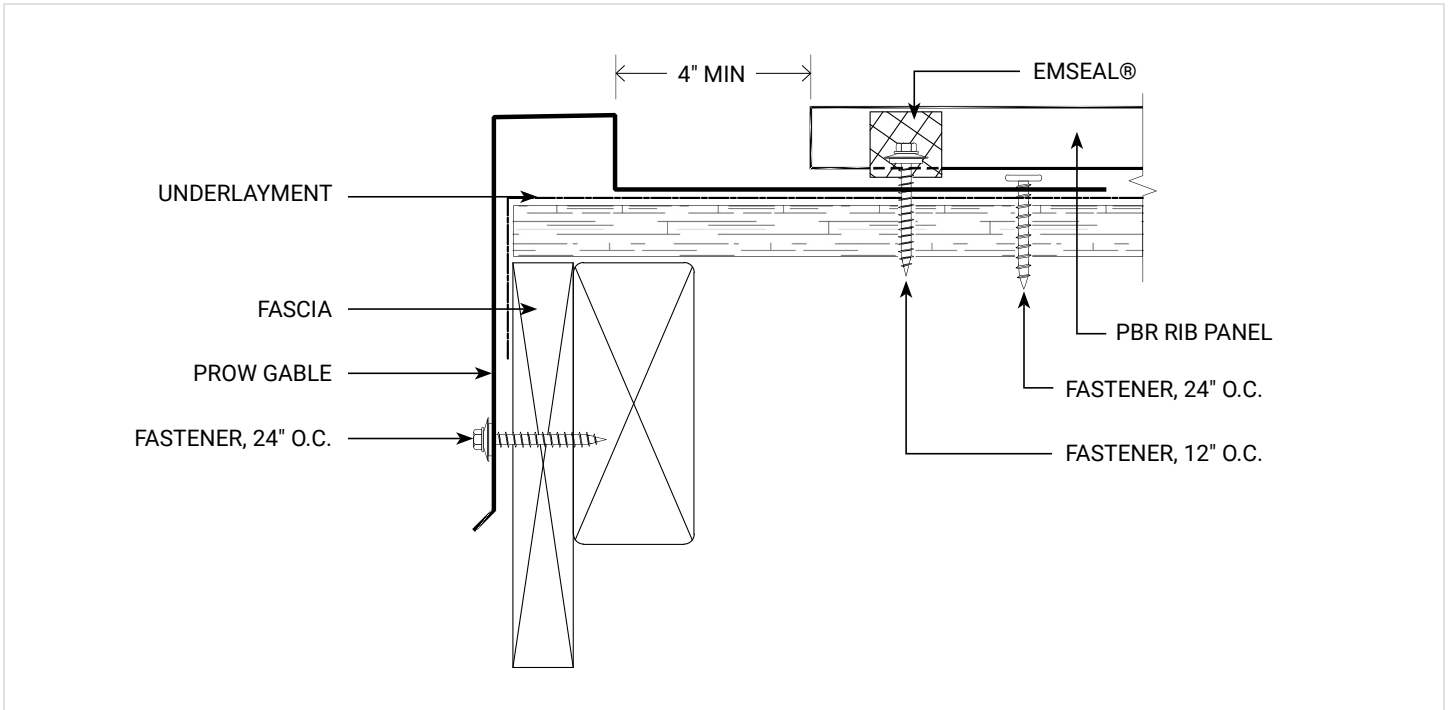

## OVERALL DORMER

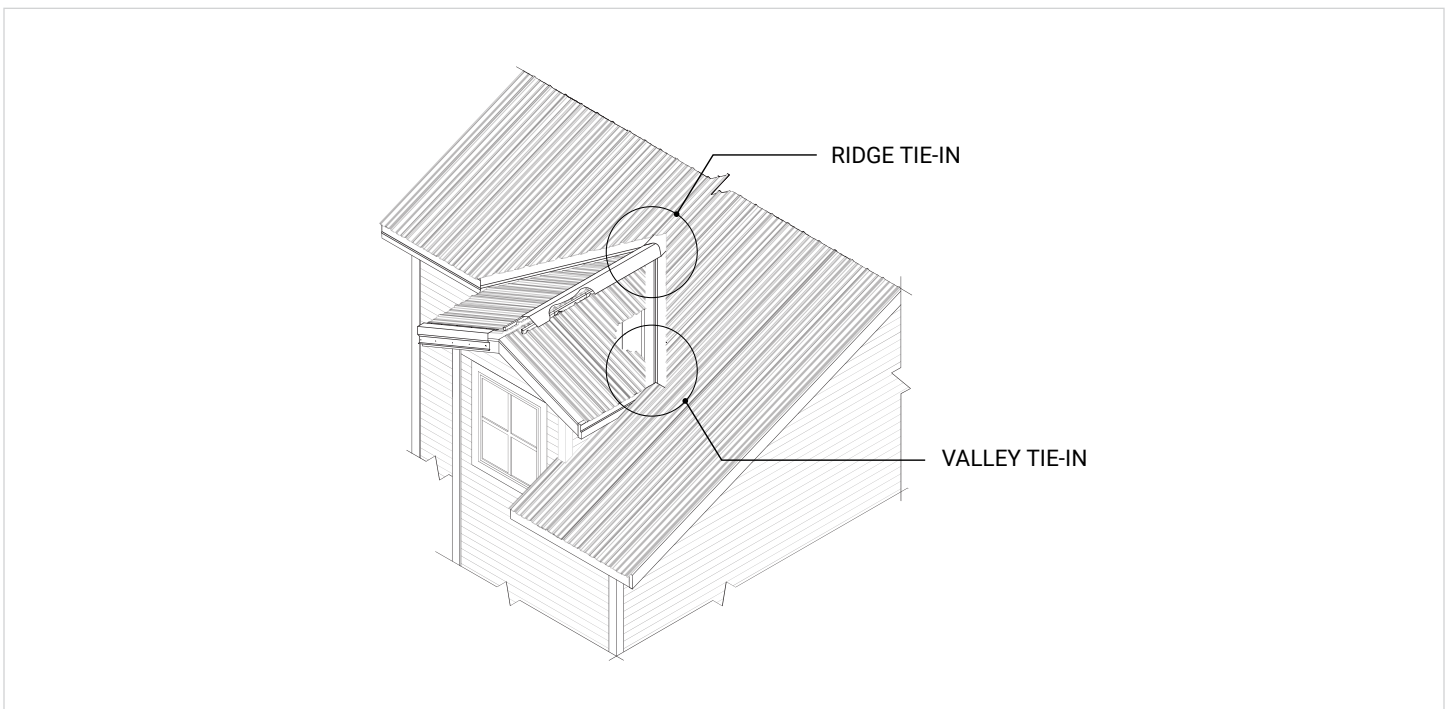

*\*Details are subject to change without notice.*

## RIDGE TIE-IN

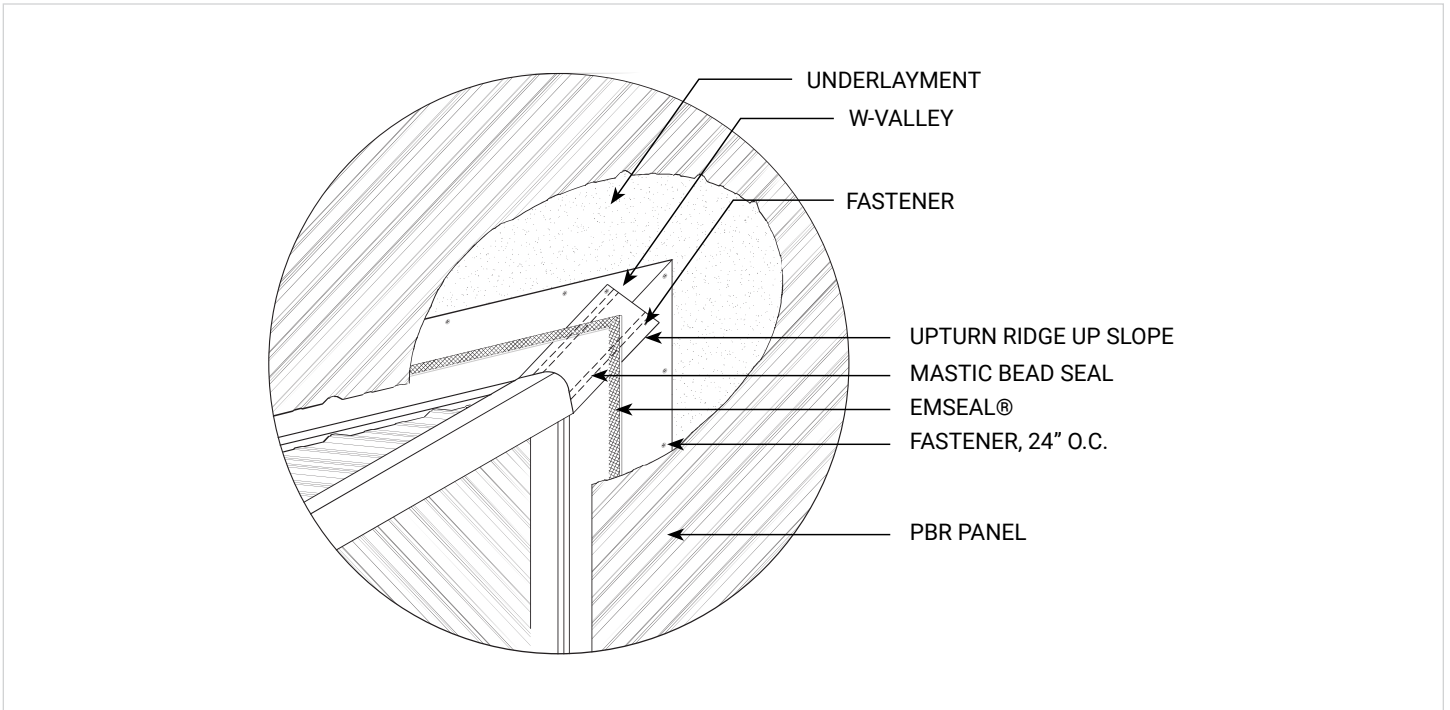

## VALLEY TIE-IN

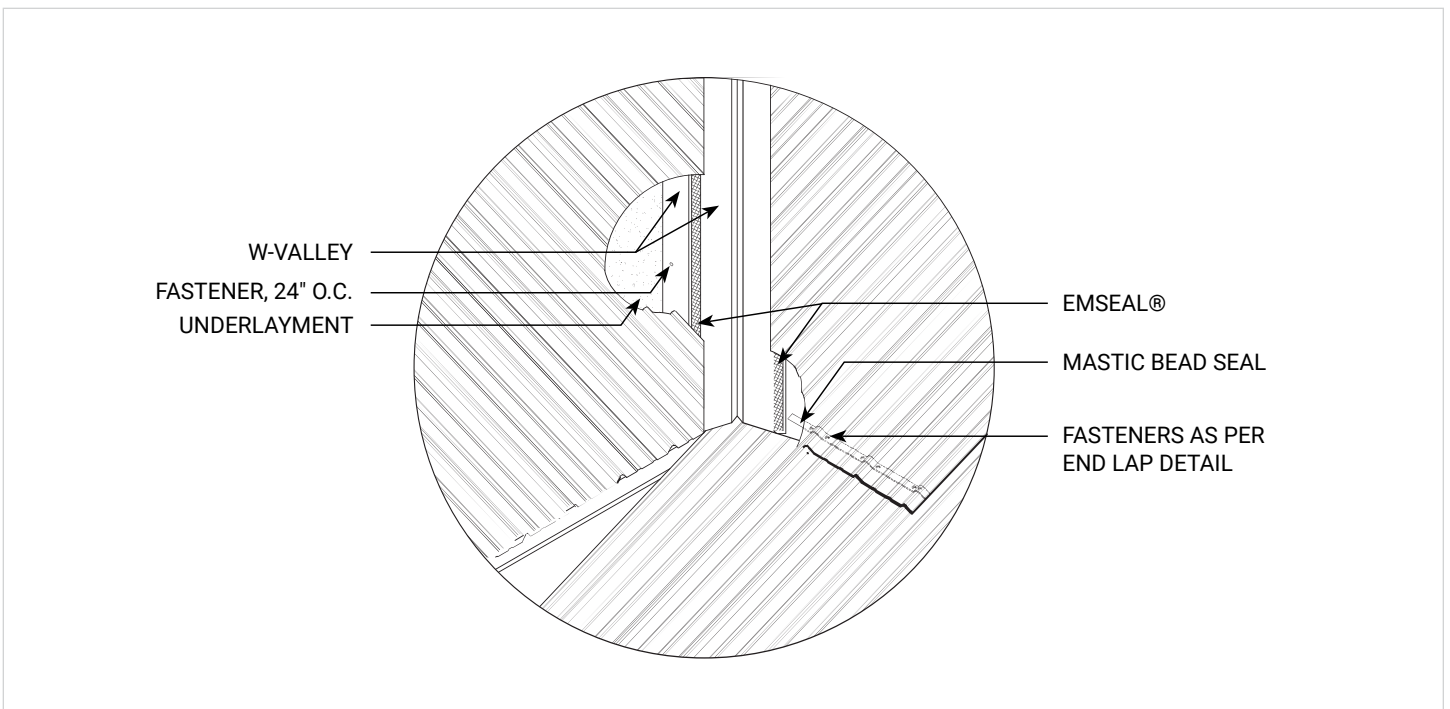

*\*Details are subject to change without notice.*

